



BM 26 W Technical Datasheet

Magnetic Level Indicator with integrated Radar Level Meter

- Can easily be isolated from the process
- Two measurement principles in one device
- Autonomous local indication with an IP68 ingress protection rating



The measurement solution with built-in redundancy

BM 26 W is based on proven bypass measurement technology. BM 26 W integrates the OPTIWAVE 7300 C FMCW Radar Level Meter for distance, level and volume measurement of liquids. It can measure level in a variety of difficult conditions: foam, agitated product surface and obstructed tank environments. It also indicates level using a permanent, IP 68 local indication without power supply.

For pressures from 40 to 120 bar / 580 to 1740 psig and temperatures from 200 to 300°C / 390 ... 570°F, we recommend our BM 26A bypass level indicator. For pressures more than 120 bar / 1740 psig and temperatures higher than 300°C / 570°F, we recommend our BW 25 displacer-type level indicator.

For further information on the integrated radar level meter, please refer to the Technical Datasheet for the OPTIWAVE 7300 C.

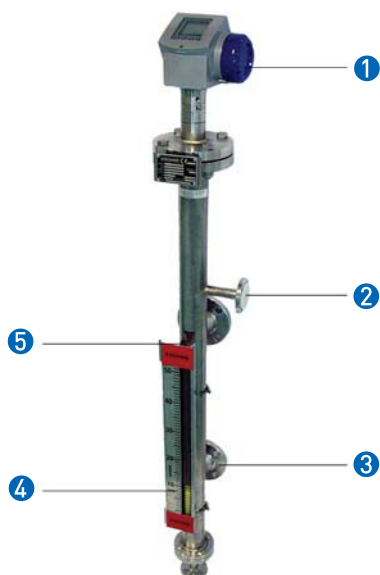

- ① 2-wire radar level meter
- ② Option: drains and vents
- ③ Option: side or inline process connection at the bottom of the chamber
- ④ Magnetically-coupled level indicator
- ⑤ Accessory: limit switches

Highlights

- Configured system - easy to measure
- Redundant measurement system
- Ideal for tanks with obstructed environments
- PACTware and DTMs included as standard
- Optional second current output
- Optional limit switches
- Optional approval for EEx i or EEx d applications
- Removable housing under process conditions

Industries

- Oil & Gas
- Petrochemicals
- Power
- Water

Applications

- Process and storage tanks
- Steam crackers
- Boilers

Applications

1. Measurement of liquids in tanks with obstructed environments

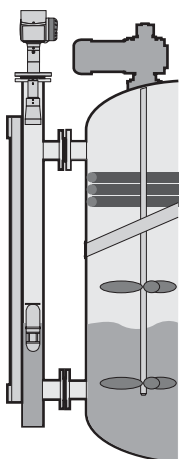

If the tank is full of obstructions such as agitators and reinforcements, we recommend the **BM 26 W** bypass level indicator. It can also measure accurately in agitated conditions and in the presence of foam.

2. Redundant local indication without power supply

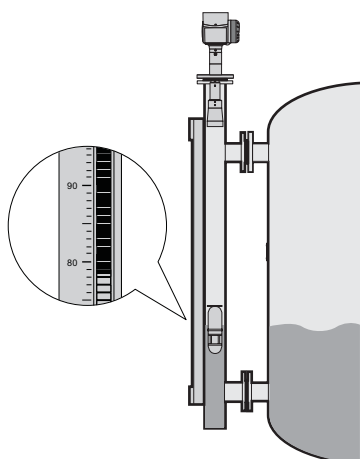

The **BM 26 W** has a float and indicating tube for indicating level on a highly visible column of yellow and black rotating flaps. No power is needed. It is also possible to fit limit switches, if you choose this option. Ex approval is optional.

Technical Data

Input

Device	Magnetic level indicator with integrated radar level meter
Function 1	K-band FMCW radar
Function 2	Float magnetically coupled to mechanical level indicator
Parameter	Level, distance, volume and reflectivity
Measuring range	0.5...6 m / 1.6...20 ft

Output

Output signal (Output 1)	4...20 mA HART® or 3.8...20.5 mA acc. to NAMUR NE 43
Output signal (Output 2)	4...20 mA (no HART® signal) or 3.8...20.5 mA acc. to NAMUR NE 43 ①
Resolution	±3 µA
Temperature drift	Typically 50 ppm/K
Error signal	High: 22 mA; Low: 3.6 mA acc. to NAMUR NE 43

Reference conditions acc. to EN 60770

Temperature	+20°C ±5°C / +70°F ±10°F
Pressure	1013 mbar abs. ±20 mbar / 14.69 psig ±0.29 psig
Relative air humidity	60% ±15%

Accuracy

Radar level meter	
Resolution	1 mm / 0.04"
Repeatability	±1 mm / ±0.04"
Accuracy	±3 mm / ±0.12", when distance < 10 m / 33 ft
Magnetic level indicator	
Repeatability	±10mm / ±0.4"
Accuracy	±10mm / ±0.4"

Process conditions

Ambient temperature	-40...+80°C / -40...+175°F (EEx i: see supplementary operating instructions or approval certificates)
Storage temperature	-40...+85°C / -40...+185°F
Process temperature	-40...+200°C / -40...+390°F (EEx i: see supplementary operating instructions or approval certificates)
Thermal shock resistance	100°C/min
Operating pressure	-1...40 bar / -14.5...580 psig; subject to process connection used and flange temperature
Vibration resistance	IEC 68-2-6 and EN 50178 (10...57 Hz: 0.075 mm / 57...150 Hz: 1g)
Product density	0.5...3 kg/l / 31...187 lb/ft³
Viscosity	≤5000 mPas / ≤3.360 lb/fts
Protection category	IP 66/67 equivalent to NEMA 6-6X

Material

Transmitter	
Housing	Aluminium; Stainelss steel (1.4404 / 316 L) ①
Wetted parts	Stainless steel (1.4404 / 316 L)
Process fitting	Stainless steel (1.4404 / 316 L)
Gaskets	FKM/FPM (-40...+200°C / -40...+390°F); Kalrez® 6375 (-20...+200°C / -5...+390°F)
Weather protection (Option)	Stainless steel (1.4301 / 304)

Bypass chamber	
Chamber	Stainless steel (1.4404 / 316 L)
Float	Stainless steel (1.4404 / 316 L), Titanium
Gaskets	Klingerit (-196...+400°C / -320...+750°F) ②

Process connections

Flange	DN15...50 (PN40); ½"...2" (150 lb / 300 lb)
--------	---

Drain and vent connections

Drain	G 3/8; options: G 1/2; NPT 3/8, 1/2, 3/4; DN15, 25 (PN40); 1/2"...1" (150 lb / 300 lb)
Vent	DN25 (PN40); 1" (150 lb / 300 lb) ①

Electrical connections

Instrument terminal 1 - Non-Ex / EEx i	14...30 VDC ③
Instrument terminal 1 - EEx d	20...36 VDC ③
Instrument terminal 2 - Non-Ex/ EEx i/ EEx d	10...30 VDC ④
Cable entry	M20x1.5; NPT 1/2; G 1/2
Cable tightening capacity	0.5...1.5 mm²

Human interface

Display 1	9 lines, 160 x 160 pixels in 8-step greyscale with 4-button keypad
Display 2	Indicator column - magnetically-coupled, yellow/black rotating flaps
Operating languages	English and a 2nd language: German, French, Italian, Spanish, Portuguese, Japanese, Chinese (Mandarin) or Russian

Design codes

Conformity to pressure equipment directives	PED 97/23/EC
Pressure vessel construction code	CODAP® 2000
Optional codes	NACE MRO175 / ISO 15156

Approvals

ATEX	ATEX II G 1, 1/2, 2 EEx ia IIC T6...T3; ATEX II G 1/2, 2 EEx d[ia] IIC T6...T3 ⑤
------	--

Variants, options and accessories

Variants	C: two side connections;
	F: top side connection and bottom inline connection
Options	Integrated LCD display with sun cover;
	2nd current output;
	Indicator scale units - m+cm, ft+in or % ⑥
Accessories	Weather protection;
	Limit switches

- ① optional
- ② subject to process conditions
- ③ min/max. value for an output of 22 mA at the terminal
- ④ min/max. value for an output of 22 mA at the terminal (additional power supply needed - output only)
- ⑤ this is a set of approvals
- ⑥ volume graduation on request

Technical data: optional level switches

	Standard (Non-Ex) switches					
Type code	MS20 STD/LC/PC/NN/BT	MS15 STD/LC/PC/NO/BT	MS15 STD/LC/AL/NN/HT	MS15 STD/LC/AL/NO/HT	MS15 STD/HC/PC/NN/BT	MS15 STD/HC/AL/NN/HT
Version	Low price, standard	NAMUR	High-temperature	NAMUR, high-temperature	High-power cut-out	High-power cut-out, high temperature

Input

Device	Level switch mounted on the side of the BM 26 bypass chamber					
Function	Reed switch that is magnetically actuated by float in BM 26 bypass chamber					
Parameter	Level detection					
Switching capacity	30 VA; 0.5 A; 230 VAC	①	20 VA; 1.5 A; 250 VAC	①	3...100VA; 1.5 A; 250 VAC	3...100VA; 1.5 A; 250 VAC

Accuracy

Hysteresis	Not applicable
------------	----------------

Process conditions

Ambient temperature	-20...+120°C / -4...+250°F ②					
Process temperature	-40...+250°C / -40...+480°F	-40...+250°C / -40...+480°F	-40...+300°C / -40...+570°F	-40...+300°C / -40...+570°F	-40...+250°C / -40...+480°F	-40...+300°C / -40...+570°F
Protection category	IP 65 equivalent to NEMA 4-4X					

Material

Switch housing	Polycarbonate	Polycarbonate	Aluminium	Aluminium	Polycarbonate	Aluminium
Bracket	Stainless steel					
Clamp	Stainless steel					

Electrical connections

Cable entry	PG 9	PG 13.5	M20 x 1.5 ③	M20 x 1.5 ③	PG 13.5	M20 x 1.5 ③
-------------	------	---------	-------------	-------------	---------	-------------

① according to NAMUR 19234. Connect to a NAMUR amplifier.

② specify temperature if an insulation jacket is used

③ Optional: M25 x 1.5 or NPT $\frac{3}{4}$. Cable fitting not supplied.

	Exi-approved switches			
Type code	MS20 EXI/LC/PC/NN/BT	MS15 EXI/LC/PC/NO/BT	MS15 EXI/LC/AL/NN/HT	MS15 EXI/LC/AL/NO/HT
Version	low price, standard	NAMUR	high-temperature	NAMUR, high-temperature

Input

Device	Level switch mounted on the side of the BM 26 bypass chamber			
Function	Reed switch that is magnetically actuated by float in BM 26 bypass chamber			
Parameter	Level detection			
Switching capacity	0.5 A ①	②	1.5 A ①	②

Accuracy

Hysteresis	Not applicable
------------	----------------

Process conditions

Ambient temperature	③			
Process temperature	③	③	③	③
Protection category	IP 65 equivalent to NEMA 4-4X			

Material

Switch housing	Polycarbonate	Polycarbonate	Aluminium	Aluminium
Bracket	Stainless steel			
Clamp	Stainless steel			

Electrical connections

Power supply characteristics	See supplementary operating instructions or approval certificates.			
Cable entry	PG 9	PG 13.5	M20 x 1.5 ④	M20 x 1.5 ④

Approvals

ATEX	ATEX II 1 G EEx ia IIC T3...T6
------	--------------------------------

- ① Only connect to a certified intrinsically-safe power supply. Safety values: see supplementary operating instructions or approval certificates.
- ② according to NAMUR 19234. Connect a NAMUR amplifier.
- ③ Dependant on temperature class: see supplementary operating instructions or approval certificates.
- ④ Optional: M25 x 1.5 or NPT $\frac{3}{4}$. Cable fitting not supplied.

	Exd-approved switches		
Type code	MS15 EXD/LC/AL/NN/HT	MS15 EXD/LC/AL/NO/HT	MS15 EXD/HC/AL/NN/HT
Version	high-temperature	NAMUR, high-temperature	high-power cut-out, high-temperature

Input

Device	Level switch mounted on the side of the BM 26 bypass chamber		
Function	Reed switch that is magnetically actuated by float in BM 26 bypass chamber		
Parameter	Level detection		
Switching capacity	20 VA; 1.5 A; 250 VAC	①	1.5 A ②

Accuracy

Hysteresis	Not applicable		
------------	----------------	--	--

Process conditions

Ambient temperature	③		
Process temperature	③	③	③
Protection category	IP 65 equivalent to NEMA 4-4X		

Material

Switch housing	Aluminium	Aluminium	Aluminium
Bracket	Stainless steel		
Clamp	Stainless steel		

Electrical connections

Cable entry	M20 x 1.5 ④	M20 x 1.5 ④	M20 x 1.5 ④
-------------	-------------	-------------	-------------

Approvals

ATEX	ATEX II 1/2 G EEx d ia IIC T3...T6		
------	------------------------------------	--	--

① according to NAMUR 19234. Connect a NAMUR amplifier.

② Only connect to a certified intrinsically-safe power supply. Safety values: see supplementary operating instructions or approval certificates.

③ Dependant on temperature class: see supplementary operating instructions or approval certificates.

④ Optional: M25 x 1.5 or NPT $\frac{3}{4}$. Cable fitting not supplied.

Guidelines for maximum operating pressure

Note:

Ensure that meters are used within their operating limits. Observe the following requirements.

Flanged connections for BM 26 chamber according to EN 1092-1:

Pressure / temperature de-rating for 316 L (1.4404) stainless steel meters

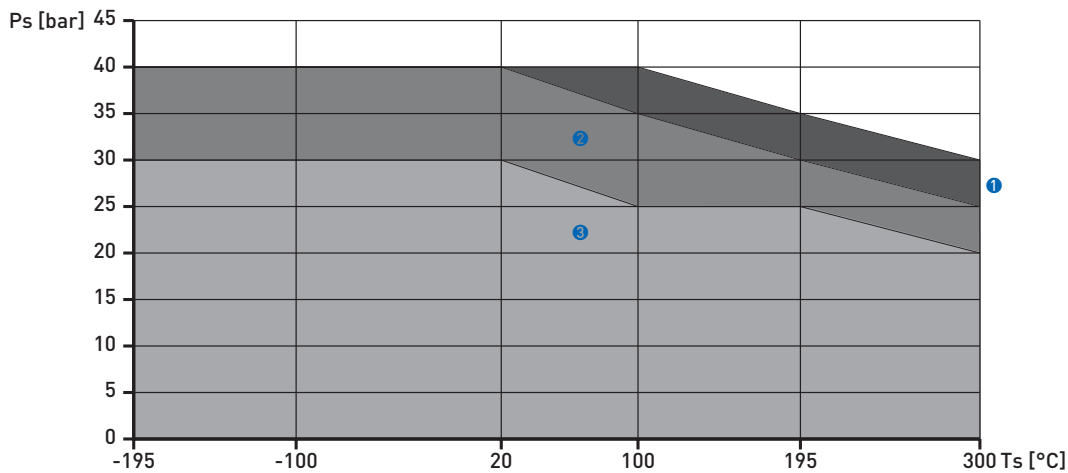

- ① Loose and Welding Neck PN40 flanges for sizes DN15 and DN20
- ② Loose and Welding Neck PN40 flange for size DN25
- ③ Loose and Welding Neck PN40 flanges for sizes DN40 and DN50

Flanged connections for BM 26 chamber according to ASME:

Pressure / temperature de-rating for 316 L (1.4404) stainless steel meters

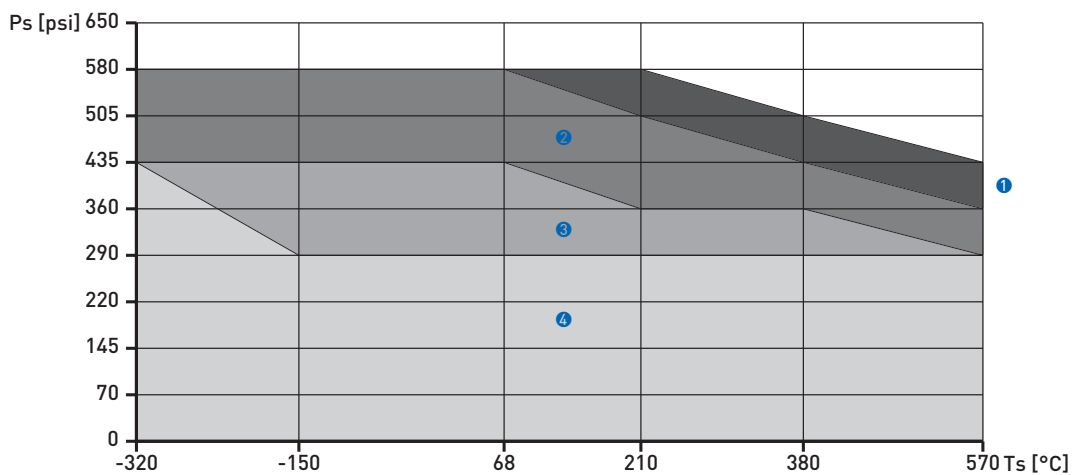

- ① ASME 300 lb flanges for sizes 1/2" and 3/4"
- ② ASME 300 lb flange for size 1"
- ③ ASME 300 lb flanges for sizes 1 1/2" and 2"
- ④ ASME 150 lb flanges for sizes 1/2", 3/4", 1, 1 1/2", and 2"

Dimensions and Weights

Variant C: two side process connections

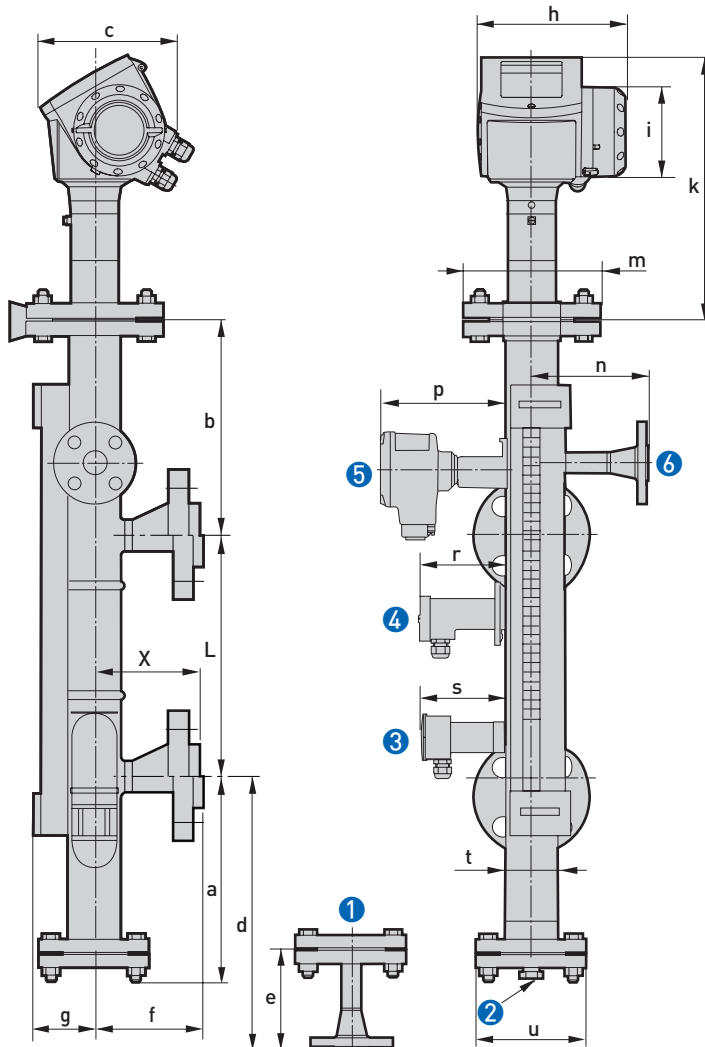

- ① Optional drain with welding neck flange connection
- ② Optional drain with G or NPT plug
- ③ Optional MS20 limit switch
- ④ Optional MS15 limit switch for low-temperature applications
- ⑤ Optional MS15 Exd limit switch for high-temperature and Ex d applications
- ⑥ Optional vent with welding neck flange connection

Note:

- Cable glands are delivered on demand with non-Ex, EEx i- and EEx d-approved devices.
- Non-Ex and EEx i fittings are plastic and EEx d fittings are metallic. Non-Ex fittings are black and EEx i fittings are blue.
- The diameter of the outer sheath of the cable must be 6...12 mm or 0.2...0.5".

Dimensions in mm

	Dimensions [mm]																		
	a	b	c	d	e	f	X	g	h	i	k	L	m	n	p	r	s	t	u
Bypass chamber C ①	165	260	217	295 ②	116	115	③	72	180	∅ 109	305	500 ... 6000	∅16 5	140 ④	146 ⑤	100 ⑥	98 ⑦	∅72 x 2.3	∅ 130

- ① with two side process connections
- ② with optional drain (welding neck flange)
- ③ welding neck flanges: refer to "Process connection length, X" table at the end of this section
- ④ with optional vent
- ⑤ with optional MS15 limit switch for high-temperature and Ex d applications
- ⑥ with optional MS15 limit switch for low-temperature applications
- ⑦ with optional MS20 limit switch

Dimensions in inches

	Dimensions [inches]																		
	a	b	c	d	e	f	X	g	h	i	k	L	m	n	p	r	s	t	u
Bypass chamber C ①	6.5	10.2	8.5	11.6 ②	4.6	4.5	③	2.8	7.0	∅4. 3	12.0	20 ... 236	∅6. 5	5.5 ④	5.7 ⑤	4.0 ⑥	3.9 ⑦	∅2. 8 x 0.09	∅5. 1

- ① with two side process connections
- ② with optional drain (welding neck flange)
- ③ welding neck flanges: refer to "Process connection length, X" table at the end of this section
- ④ with optional vent
- ⑤ with optional MS15 limit switch for high-temperature applications
- ⑥ with optional MS15 limit switch for low-temperature applications
- ⑦ with optional MS20 limit switch

Weight in kg and lbs

Converter and chamber	Weight when L=1000 mm	Weight when L=40 inches	Weight for every additional 100 mm	Weight for every additional 4 inches
Chamber type	[kg]	[lbs]	[kg]	[lbs]
Bypass chamber	23.9	52.7	0.5	1.1
MS15 BT limit switch ①	0.13	0.3	-	-
MS15 HT limit switch ②	1.2	2.6	-	-
MS20 limit switch	0.086	0.2	-	-

- ① for low-temperature applications
- ② for high-temperature applications

Variant F: top side and bottom inline process connections

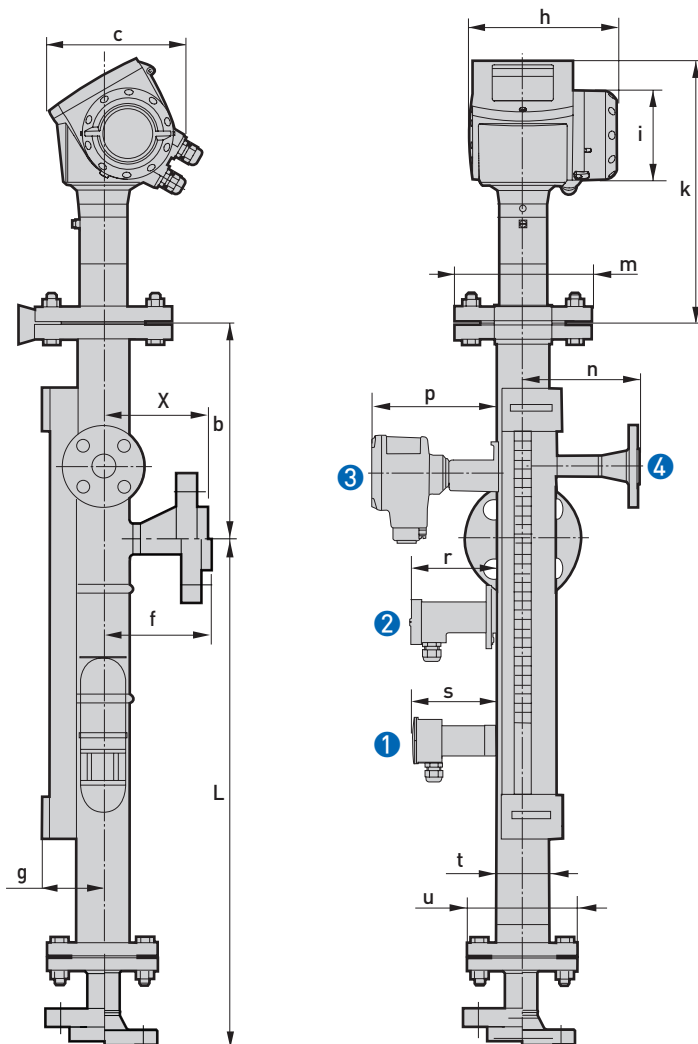

- ① Optional MS20 limit switch
- ② Optional MS15 limit switch for low-temperature applications
- ③ Optional MS15 limit switch for high-temperature or Ex d applications
- ④ Optional vent with welding neck flange connection

Note:

- Cable glands are delivered on demand with non-Ex, EEx i- and EEx d-approved devices.
- Non-Ex and EEx i fittings are plastic and EEx d fittings are metallic. Non-Ex fittings are black and EEx i fittings are blue.
- The diameter of the outer sheath of the cable must be 6...12 mm or 0.2...0.5".

Dimensions in mm

	Dimensions [mm]															
	b	c	f	X	g	h	i	k	L	m	n	p	r	s	t	u
Bypass chamber F ①	260	165	115	②	72	180	∅ 109	305	500 ... 6000	∅165	140 ③	146 ④	100 ⑤	98 ⑥	∅72 x 2.3	∅ 130

- ① with top side and bottom in-line process connections
- ② welding neck flanges: refer to "Process connection length, X" table at the end of this section
- ③ with optional vent (welding neck flange)
- ④ with optional MS15 limit switch for high-temperature and Ex d applications
- ⑤ with optional MS15 limit switch for low-temperature applications
- ⑥ with optional MS20 limit switch

Dimensions in inches

	Dimensions [inches]															
	b	c	f	X	g	h	i	k	L	m	n	p	r	s	t	u
Bypass chamber F ①	10.2	6.5	4.5	②	2.8	7.0	∅4.3	12.0	20 ... 236	∅6.5	5.5 ③	5.7 ④	4.0 ⑤	3.9 ⑥	∅2.8 x 0.09	∅5.1

- ① with top side and bottom in-line process connections
- ② welding neck flanges: refer to "Process connection length, X" table at the end of this section
- ③ with optional vent (welding neck flange)
- ④ with optional MS15 limit switch for high-temperature and Ex d applications
- ⑤ with optional MS15 limit switch for low-temperature applications
- ⑥ with optional MS20 limit switch

Weight in kg and lbs

Converter and chamber	Weight when L=1000 mm	Weight when L=40 inches	Weight for every additional 100 mm	Weight for every additional 4 inches
Chamber type	[kg]	[lbs]	[kg]	[lbs]
Bypass chamber	23.9	52.7	0.5	1.1
MS15 BT limit switch ①	0.13	0.3	-	-
MS15 HT limit switch ②	1.2	2.6	-	-
MS20 limit switch	0.086	0.2	-	-

- ① for low-temperature applications
- ② for high-temperature applications

Tables for process connection length, X

Process connection length, X, in mm (EN welding neck flanges)

Nominal size	Pressure rating	Process connection length, X
DN	PN	[mm]
15	40	79.5
20	40	81.5
25	40	81.5
40	40	86.5
50	40	89.5

Process connection length, X, in inches (EN welding neck flanges)

Nominal size	Pressure rating	Process connection length, X
DN	PN	[inches]
15	40	3.13
20	40	3.21
25	40	3.21
40	40	3.41
50	40	3.52

Process connection length, X, in mm (ASME welding neck flanges)

Nominal size	Pressure rating	Process connection length, X
ASME		[mm]
½"	150LB	89.5
¾"	150LB	93.5
1"	150LB	97.5
1½"	150LB	103.5
2"	150LB	104.5
½"	300LB	93.5
¾"	300LB	98.5
1"	300LB	103.5
1½"	300LB	109.5
2"	300LB	111.5

Process connection length, X, in inches (ASME welding neck flanges)

Nominal size	Pressure rating	Process connection length, X
ASME		[inches]
½"	150LB	3.52
¾"	150LB	3.84
1"	150LB	4.07
1½"	150LB	4.11
2"	150LB	3.68
½"	300LB	3.68
¾"	300LB	3.88
1"	300LB	4.07
1½"	300LB	4.31
2"	300LB	4.39