

UFM 530 HT Handbook

Inline ultrasonic flowmeter for high-temperature liquids

Hardware version: 2134721100-200
Software μ P2: 90-05

All rights reserved. It is prohibited to reproduce this documentation, or any part thereof, without the prior written authorisation of KROHNE Messtechnik GmbH.

Subject to change without notice.

Copyright 2013 by
KROHNE Messtechnik GmbH - Ludwig-Krohne-Str. 5 - 47058 Duisburg (Germany)

1	Safety instructions	5
<hr/>		
1.1	Software history	5
1.2	Intended use	5
1.3	Certifications	5
1.3.1	CE-certification	5
1.4	Safety instructions from the manufacturer	6
1.4.1	Copyright and data protection	6
1.4.2	Disclaimer	6
1.4.3	Product liability and warranty	7
1.4.4	Information concerning the documentation	7
1.4.5	Warnings and symbols used	8
1.5	Safety instructions for the operator	8
2	Device description	9
<hr/>		
2.1	Scope of delivery	9
2.2	Device description	10
2.3	Nameplates	10
2.4	Example nameplate	11
3	Installation	12
<hr/>		
3.1	General notes on installation	12
3.2	Storage	12
3.3	Transport	12
3.4	Inlet and outlet	13
3.5	Mounting	14
3.5.1	Mounting position of the flow sensor	14
3.5.2	Mounting location of the flow sensor	14
3.5.3	Insulation	17
3.5.4	Pipe flanges	17
3.5.5	Pipes with cathodic protection	18
4	Electrical connections	19
<hr/>		
4.1	Safety instructions	19
4.2	Power supply of the converter	19
4.3	Connection of signal cables	21
4.4	Electrical connections of the signal inputs and outputs	22
4.4.1	Non Ex versions	22
4.4.2	Ex versions	25
4.5	Connection diagram examples	29
4.5.1	Current output	29
4.5.2	Pulse output	30
4.5.3	Digital input	31
4.5.4	Analog input	32
5	Start-up	33
<hr/>		

5.1 Start-up procedure.....	33
6 Operation	34
<hr/>	
6.1 Signal converter: front panel and operating keys	34
6.2 Available versions.....	35
6.3 Signal converter: menu structure.....	36
6.4 Important menu functions in detail.....	49
6.4.1 Error/totalizer (Menu 0.00.00)	49
6.4.2 View error messages / reset error messages (menu 0.00.01 and 0.00.02).....	51
6.4.3 Full-scale value for 100% volume and flow rate units (menu 3.01.01).....	51
6.4.4 Low-flow cut-off, cut-off "on"/"off" value (menu 3.01.05...3.01.07).....	51
6.4.5 Direction of current output (menu 3.04.02)	52
6.4.6 User-defined unit for volume flow rate and totalizer (menu 3.07.05...3.07.07).....	52
6.4.7 Plausibility filter (menu 3.07.09...3.07.11)	53
7 Service	54
<hr/>	
7.1 Electronics exchange	54
7.1.1 Exchange of the electronics unit	54
7.1.2 Replacing the mains fuse	56
7.2 Maintenance	57
7.2.1 Admonitions for replacement of flow sensor in separate systems.....	57
7.3 Cleaning	57
7.4 Spare parts availability.....	58
7.5 Availability of services	58
7.6 Returning the device to the manufacturer.....	58
7.6.1 General information.....	58
7.6.2 Form (for copying) to accompany a returned device.....	59
7.7 Disposal	59
8 Technical data	60
<hr/>	
8.1 Measuring principle.....	60
8.2 Technical data.....	61
8.3 Dimensions and weight	65
8.3.1 Flow sensors.....	65
8.3.2 UFC 030 signal converter.....	67
9 Notes	68
<hr/>	

1.1 Software history

Release date	Hardware	Software	Documentation
1990-05	2134721100-200	μP2: 90-05	MA UFM 530 HT R01
		microcontroller: 01.13	
		DSP: 10.20	

1.2 Intended use



CAUTION!

Responsibility for the use of the measuring devices with regard to suitability, intended use and corrosion resistance of the used materials against the measured fluid lies solely with the operator.



INFORMATION!

The manufacturer is not liable for any damage resulting from improper use or use for other than the intended purpose.

This product is designed for the measurement of liquids with high temperatures up to 500°C / 932°F (Ex hazardous areas are limited to 440°C / 824°F).

1.3 Certifications

1.3.1 CE-certification



The device fulfils the statutory requirements of the following EC directives:

- Electromagnetic compatibility directive (EMC directive 2004/108/EC).
- Low voltage directive (73/23/EEC), product is designed in accordance with EN IEC 61010-1 first and second edition (safety requirements for electrical equipment for measurement, control and laboratory use part 1).
- Pressure equipment directive (Module H of 97/23/EC, full quality assurance).
- ATEX directive (94/9/EC)



DANGER!

Local safety regulations shall be observed in combination with the measures special to this product to avoid dangerous situations.

1.4 Safety instructions from the manufacturer

1.4.1 Copyright and data protection

The contents of this document have been created with great care. Nevertheless, we provide no guarantee that the contents are correct, complete or up-to-date.

The contents and works in this document are subject to copyright. Contributions from third parties are identified as such. Reproduction, processing, dissemination and any type of use beyond what is permitted under copyright requires written authorisation from the respective author and/or the manufacturer.

The manufacturer tries always to observe the copyrights of others, and to draw on works created in-house or works in the public domain.

The collection of personal data (such as names, street addresses or e-mail addresses) in the manufacturer's documents is always on a voluntary basis whenever possible. Whenever feasible, it is always possible to make use of the offerings and services without providing any personal data.

We draw your attention to the fact that data transmission over the Internet (e.g. when communicating by e-mail) may involve gaps in security. It is not possible to protect such data completely against access by third parties.

We hereby expressly prohibit the use of the contact data published as part of our duty to publish an imprint for the purpose of sending us any advertising or informational materials that we have not expressly requested.

1.4.2 Disclaimer

The manufacturer will not be liable for any damage of any kind by using its product, including, but not limited to direct, indirect or incidental and consequential damages.

This disclaimer does not apply in case the manufacturer has acted on purpose or with gross negligence. In the event any applicable law does not allow such limitations on implied warranties or the exclusion of limitation of certain damages, you may, if such law applies to you, not be subject to some or all of the above disclaimer, exclusions or limitations.

Any product purchased from the manufacturer is warranted in accordance with the relevant product documentation and our Terms and Conditions of Sale.

The manufacturer reserves the right to alter the content of its documents, including this disclaimer in any way, at any time, for any reason, without prior notification, and will not be liable in any way for possible consequences of such changes.

1.4.3 Product liability and warranty

The operator shall bear responsibility for the suitability of the device for the specific purpose. The manufacturer accepts no liability for the consequences of misuse by the operator. Improper installation and operation of the devices (systems) will cause the warranty to be void. The respective "Standard Terms and Conditions" which form the basis for the sales contract shall also apply.

1.4.4 Information concerning the documentation

To prevent any injury to the user or damage to the device it is essential that you read the information in this document and observe applicable national standards, safety requirements and accident prevention regulations.

If this document is not in your native language and if you have any problems understanding the text, we advise you to contact your local office for assistance. The manufacturer can not accept responsibility for any damage or injury caused by misunderstanding of the information in this document.

This document is provided to help you establish operating conditions, which will permit safe and efficient use of this device. Special considerations and precautions are also described in the document, which appear in the form of underneath icons.

1.4.5 Warnings and symbols used

Safety warnings are indicated by the following symbols.



DANGER!

This information refers to the immediate danger when working with electricity.



DANGER!

This warning refers to the immediate danger of burns caused by heat or hot surfaces.



DANGER!

This warning refers to the immediate danger when using this device in a hazardous atmosphere.



DANGER!

These warnings must be observed without fail. Even partial disregard of this warning can lead to serious health problems and even death. There is also the risk of seriously damaging the device or parts of the operator's plant.



WARNING!

Disregarding this safety warning, even if only in part, poses the risk of serious health problems. There is also the risk of damaging the device or parts of the operator's plant.



CAUTION!

Disregarding these instructions can result in damage to the device or to parts of the operator's plant.



INFORMATION!

These instructions contain important information for the handling of the device.



LEGAL NOTICE!

This note contains information on statutory directives and standards.



• **HANDLING**

This symbol designates all instructions for actions to be carried out by the operator in the specified sequence.

➔ **RESULT**

This symbol refers to all important consequences of the previous actions.

1.5 Safety instructions for the operator



WARNING!

*In general, devices from the manufacturer may only be installed, commissioned, operated and maintained by properly trained and authorized personnel.
This document is provided to help you establish operating conditions, which will permit safe and efficient use of this device.*

2.1 Scope of delivery



INFORMATION!

Do a check of the packing list to make sure that you have all the elements given in the order.



INFORMATION!

Inspect the cartons carefully for damages or signs of rough handling. Report damage to the carrier and to the local office of the manufacturer.

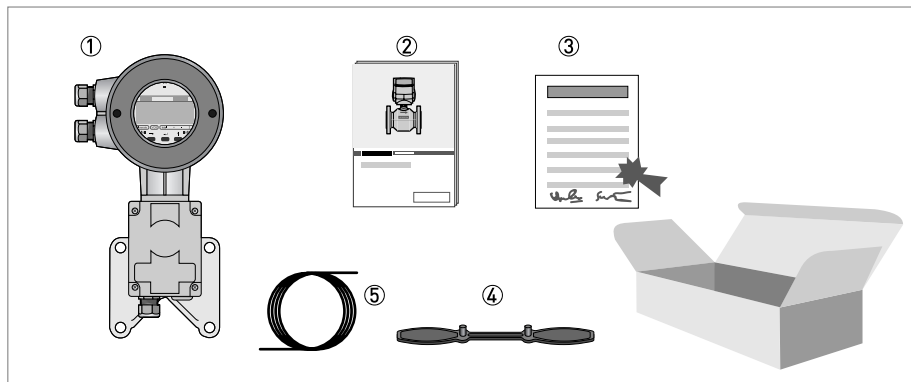

Figure 2-1: Standard scope of delivery, independent from the sensor version illustrated below

- ① Signal converter UFC 030 in ordered version
- ② Product documentation
- ③ Factory calibration report
- ④ Special wrench for opening the converter housing
- ⑤ Signal cable



INFORMATION!

Assembly materials and tools are not part of the delivery. Use the assembly materials and tools in compliance with the applicable occupational health and safety directives.

2.2 Device description

The UFM 530 HT is a bi-directional flowmeter (the arrow on the flowmeter indicates the positive direction). It consists of a UFS 500 HT flow sensor and an UFC 030 signal converter.

The signal converter is installed separately from the high-temperature flow sensor.

The flow sensor is designed for process temperatures between $-25\dots+500^{\circ}\text{C}$ / $-13\dots+932^{\circ}\text{F}$ (Ex hazardous areas are limited to $-25\dots+440^{\circ}\text{C}$ / $-13\dots+824^{\circ}\text{F}$) and is manufactured from 316 stainless steel. Depending on the diameter it uses single beam or dual beam technology. All coax cables are protected with metal tubes. On top of the flow sensor a connection box is mounted.



INFORMATION!

Other diameters, pressure classes, materials or customized designs are available on request.

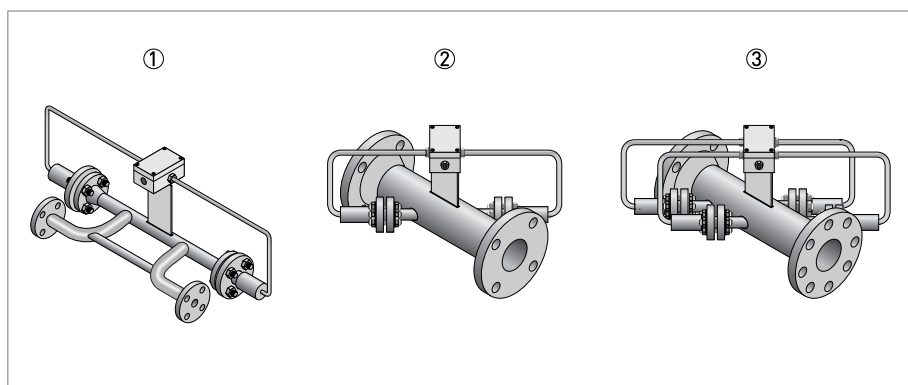

Figure 2-2: Available sensor versions

- ① Building construction "single beam" (DN25...40)
- ② Building construction "single beam" (DN50...80)
- ③ Building construction "dual beam" (\geq DN100)

2.3 Nameplates



INFORMATION!

Look at the device nameplate to ensure that the device is delivered according to your order. Check for the correct supply voltage printed on the nameplate.

2.4 Example nameplate

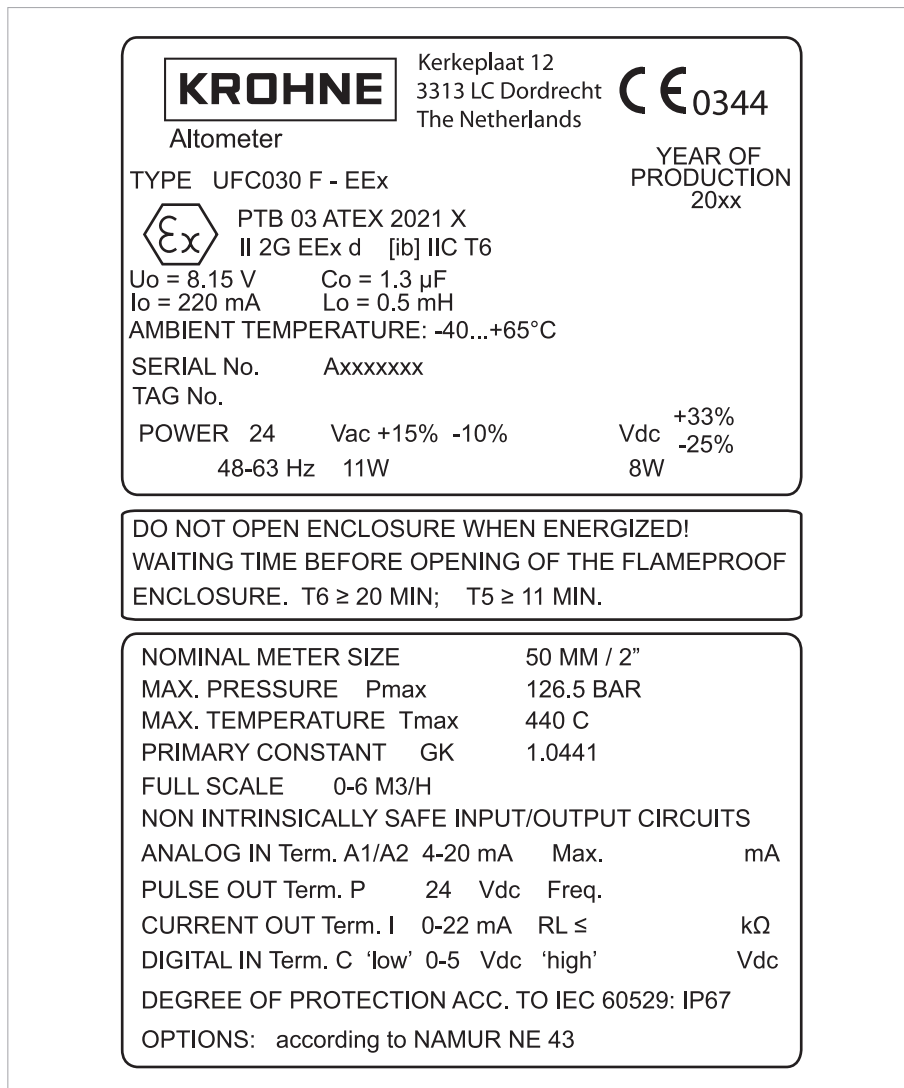

Figure 2-3: Example of nameplate

3.1 General notes on installation

**INFORMATION!**

Inspect the cartons carefully for damages or signs of rough handling. Report damage to the carrier and to the local office of the manufacturer.

**INFORMATION!**

Do a check of the packing list to make sure that you have all the elements given in the order.

**INFORMATION!**

Look at the device nameplate to ensure that the device is delivered according to your order. Check for the correct supply voltage printed on the nameplate.

3.2 Storage

- Store the device in a dry, dust-free location.
- Avoid continuous direct sunlight.
- Store the device in its original packaging.
- Storage temperature: -50...+70°C / -58...+158°F

3.3 Transport

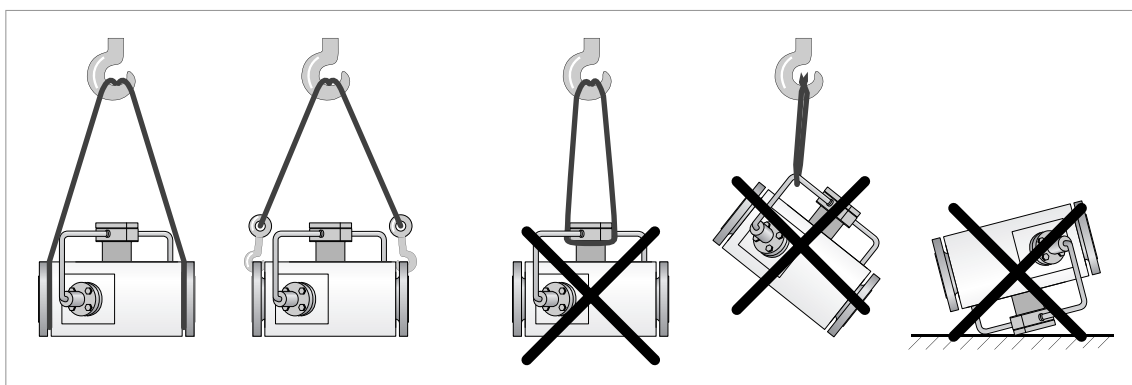

Figure 3-1: Correct lifting with the help of straps or crane hooks.

3.4 Inlet and outlet



INFORMATION!

To avoid measuring errors and to get proper measuring results an inlet section upstream and an outlet section downstream is necessary. Regard the following illustration and table and regard the information for different fluid products:

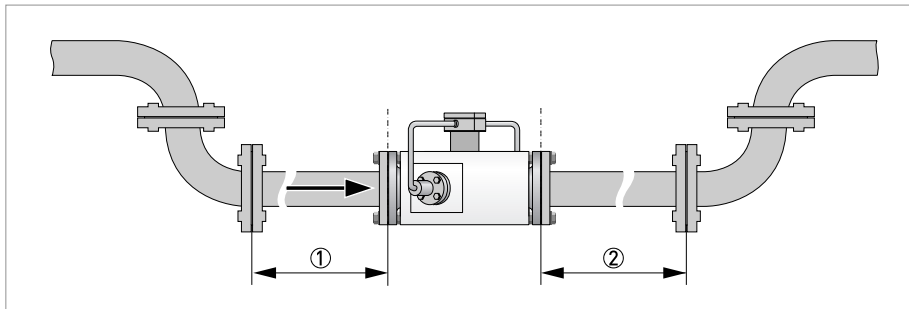

Figure 3-2: Recommended straight inlet and outlet

- ① DN25...80: ≥ 50 DN
DN100...300: ≥ 15 DN
- ② DN25...80: ≥ 10 DN
DN100...300: ≥ 5 DN



INFORMATION!

Different fluid products

To mix different fluid products, install the flow meter upstream of mixing point or at minimum distance of 30 DN downstream of the mixing point.

3.5 Mounting

3.5.1 Mounting position of the flow sensor

Installation of the flow sensor is allowed in horizontal, slightly ascending and vertical pipe sections with up going flow direction (see next section). If installed in a horizontal or slightly ascending pipeline, the connection box of the flow sensor has to be up or down.

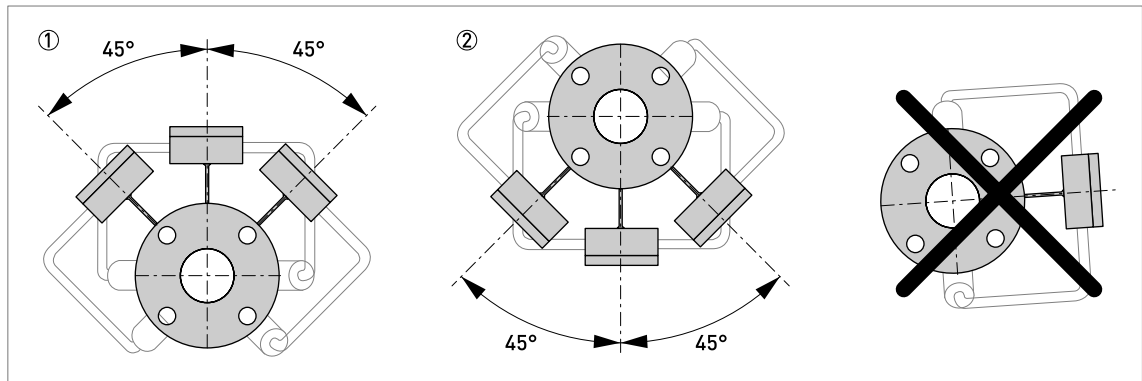

Figure 3-3: Allowed position of the flow sensor (up and down)



WARNING!

Do not unscrew the flanged transducer construction. This will cause direct contact with the high temperature liquid running through the flow sensor.

3.5.2 Mounting location of the flow sensor



INFORMATION!

For proper flow measurement the measuring tube must be completely filled at all times. When the sensors become non-wetted, a loss of signal message will be displayed. There is no damage when this occurs.

Observe the following precautions to avoid measuring errors or malfunctioning of the flow meter due to gas or air inclusions or an empty pipe.

Since gas will collect at the highest point of a pipe, installation of the flowmeter at that location should always be avoided. In long horizontal pipes the flow meter has to be installed in a slightly ascending pipe section. If not possible, ensure adequate velocity to prevent air, gas or vapour from collecting in the upper part of the flow tube.

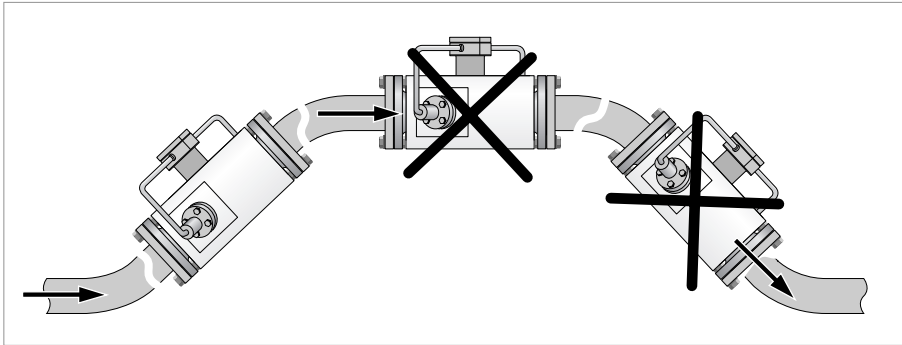

Figure 3-4: Avoid locations where gas can be present.

Also installation in a down going pipe should be avoided since a completely filled pipe may not be guaranteed due to cascading effects. Additionally flow profile distortion is possible.

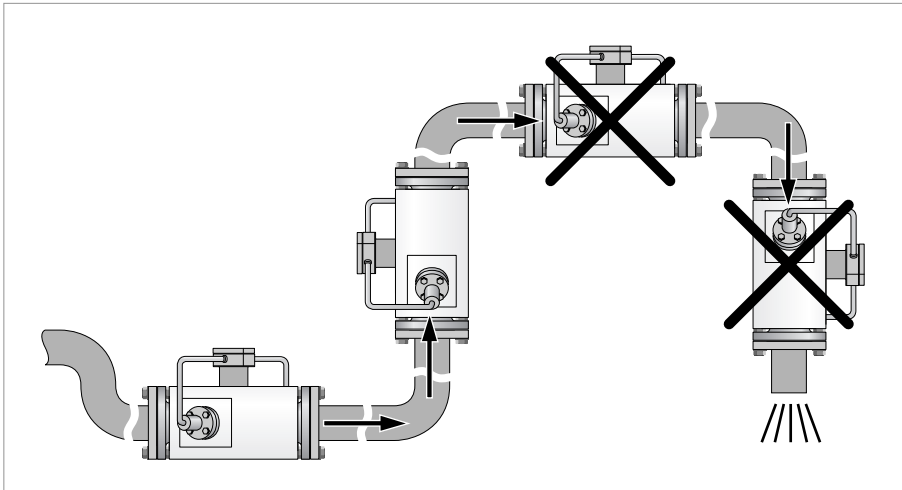

Figure 3-5: Avoid locations where gas can be present

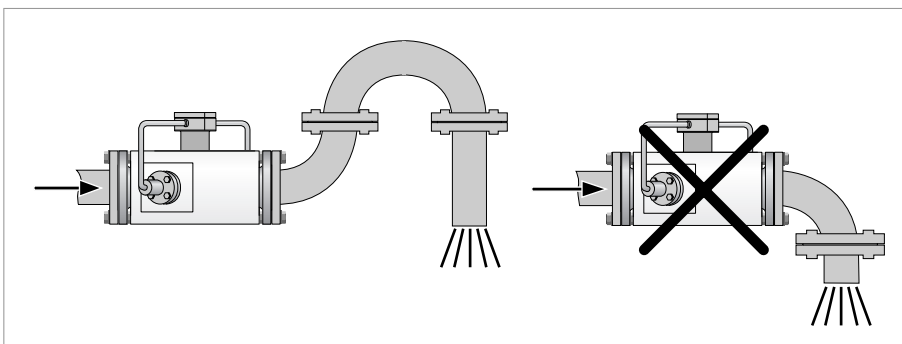

Figure 3-6: Ensure you have a completely filled pipe.

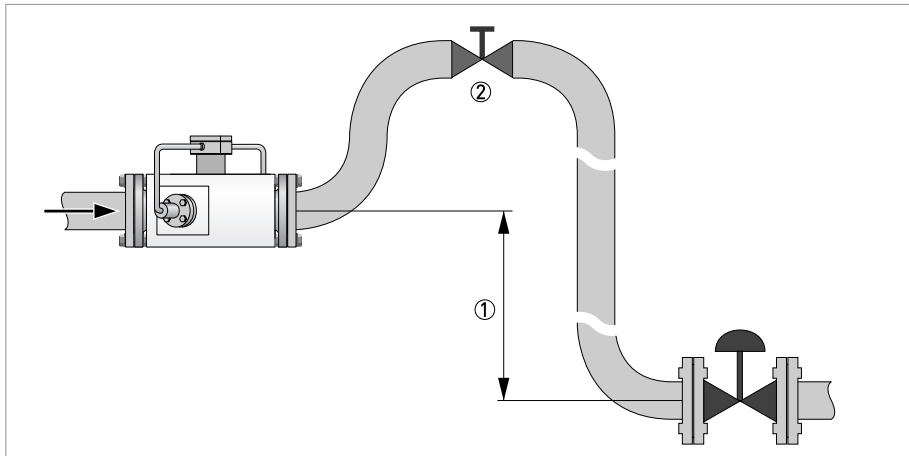

Figure 3-7: Air vent

- ① Level difference > 5 m / 16 ft
- ② Install an air vent.

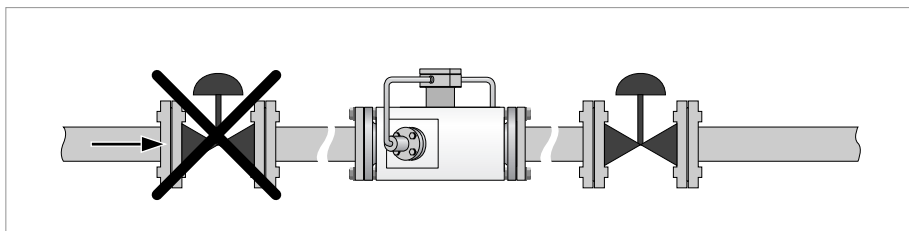

Figure 3-8: Install control valve downstream of the flow meter.

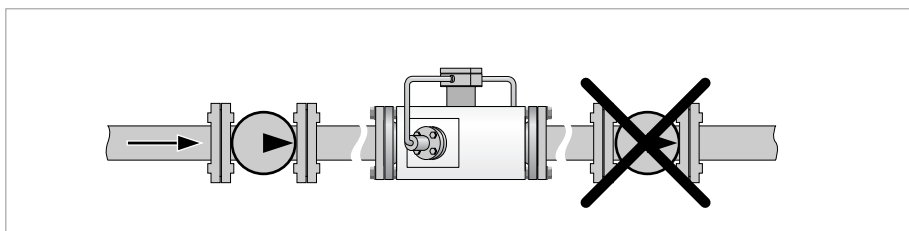

Figure 3-9: Install pump upstream of flowmeter.

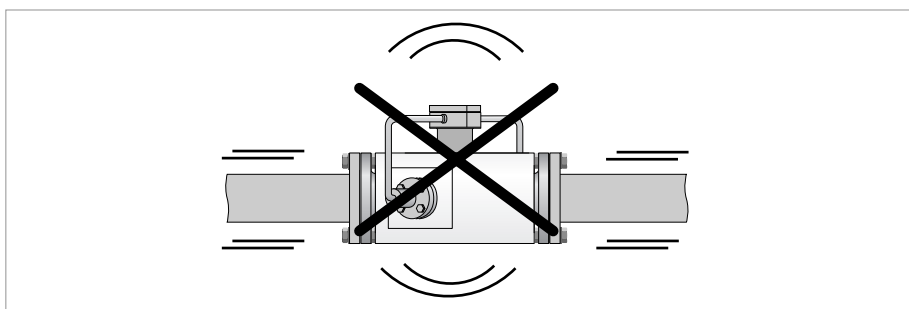

Figure 3-10: Avoid installation in vibrating pipelines.

3.5.3 Insulation



WARNING!

Complete insulation of the UFS 500 HT flow sensor is prohibited. Insulation is allowed up to the first flange of each transducer.



WARNING!

The connection box and the flanged transducers require adequate cooling by ambient air and must be protected against heat radiation by surrounding equipment.

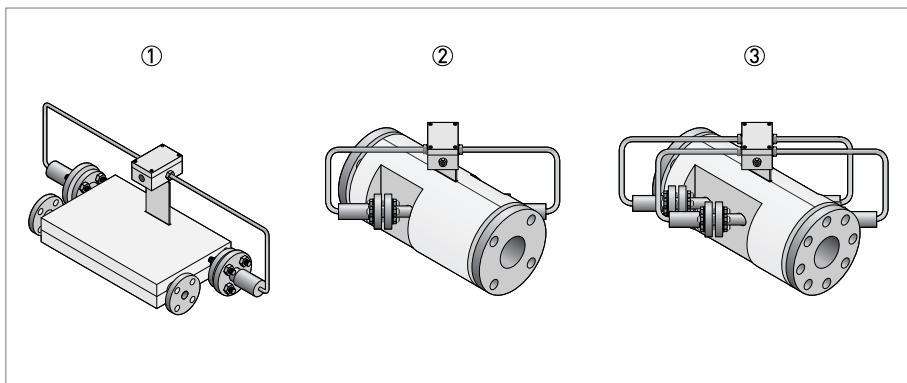

Figure 3-11: Approved insulations.

- ① Building construction "single beam" for DN25...40
- ② Building construction "single beam" for DN50...80
- ③ Building construction "dual beam" for \geq DN100

3.5.4 Pipe flanges



INFORMATION!

Refer to dimensional drawings for flange spacing and in addition allowance for thickness of gaskets.

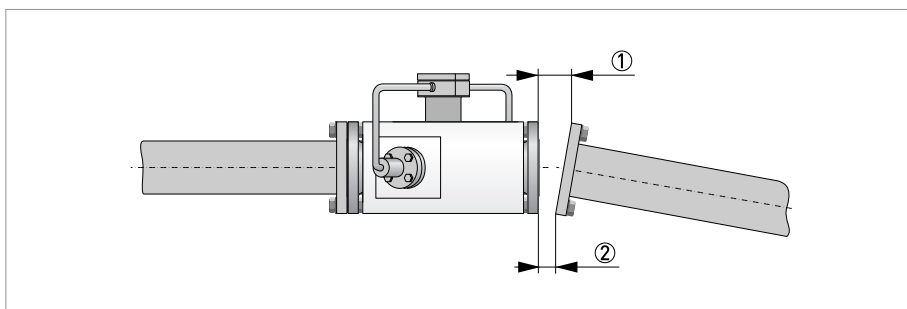

Figure 3-12: Maximum deviation between flanges

- ① L_{max}
- ② L_{min}



CAUTION!

Max. permissible deviation of pipe flange faces:
 $L_{max} - L_{min} \leq 0.5 \text{ mm} / 0.02''$

3.5.5 Pipes with cathodic protection

Pipes with electric corrosion protection are generally insulated inside and outside so that the fluid has no conductive connection to the ground. The flow meter must be insulated from the pipe. Observe the following instructions when installing the flow meter:



- The pipe flanges must be connected to each other using a copper cable (L), but must not be connected to the flowmeter.
- The bolts for the flange connections and the gaskets must be insulated. Use sleeves and washers that are made of insulating material (these must be provided by customer).

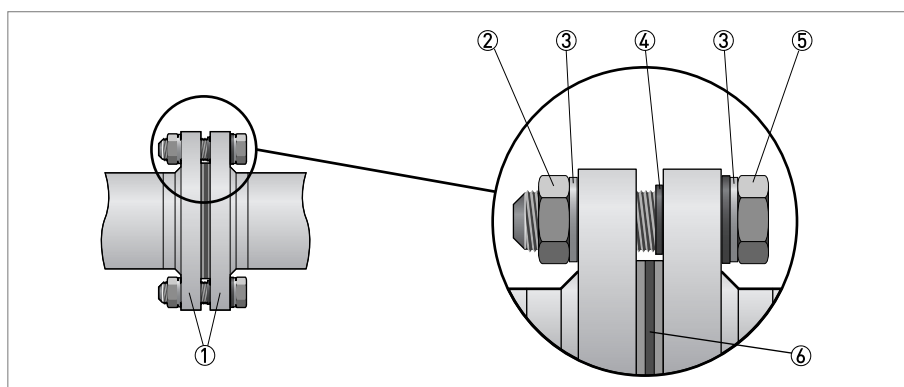

Figure 3-13: Cathodic protection

- ① Flanges (left one: of flow sensor, right one: of pipe)
- ② Nut
- ③ Washer
- ④ Insulating sleeve
- ⑤ Bolt
- ⑥ Gasket

4.1 Safety instructions

**DANGER!**

All work on the electrical connections may only be carried out with the power disconnected. Take note of the voltage data on the nameplate!

**DANGER!**

Observe the national regulations for electrical installations!

**DANGER!**

For devices used in hazardous areas, additional safety notes apply; please refer to the Ex documentation.

**WARNING!**

Observe without fail the local occupational health and safety regulations. Any work done on the electrical components of the measuring device may only be carried out by properly trained specialists.

**INFORMATION!**

Look at the device nameplate to ensure that the device is delivered according to your order. Check for the correct supply voltage printed on the nameplate.

4.2 Power supply of the converter

Environmental conditions

The flowmeter is designed to operate safe under the following conditions. Observe them before the connection to the mains supply voltage is established:

- Indoor and outdoor use, usable up to protection category IP67 according to IEC 60529 (Note: IP67 is only warranted when using suitable cabling with the cable glands and covers mounted as specified).
- Maximum altitude: up to 2000 m above sea level.
- Maximum relative humidity: up to 80%.
- Operation ambient temperature range: -40...+65°C.
- Storage temperature range: -40...+70°C.

**CAUTION!**

Never allow dirt to accumulate on the gasket of the rear (blind) cover. A dirty gasket has to be cleaned, a damaged gasket must be replaced immediately.

Before the cables can be fastened to the power supply terminal, the rear (blind) cover has to be removed.

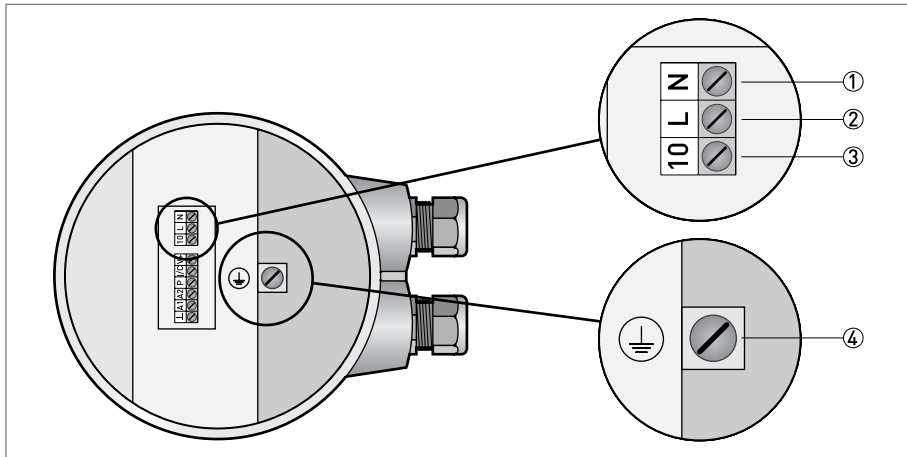

Figure 4-1: Terminals for power supply

Item number	Function	Specification
①	Neutral power supply.	
②	Life power supply.	Mains voltage AC supply: 100 VAC < U < 240 VAC (-15%, +10%), SELV AC/DC supply: 24 VDC (-25%, +33%), 24 VAC (-10%, +15%).
③	Reserved ground connection.	Not for protective earthing.
④	Protective ground connection (PE), Functional ground connection (FE).	Protective conductor clamp terminal. Conductors up to 4 mm ² (11 AWG) need to be connected to this terminal.

4.3 Connection of signal cables

Connect the signal cable from the connection box of the UFS 500 HT sensor to the UFC 030 signal converter according to underneath drawings for the single beam and dual beam construction.

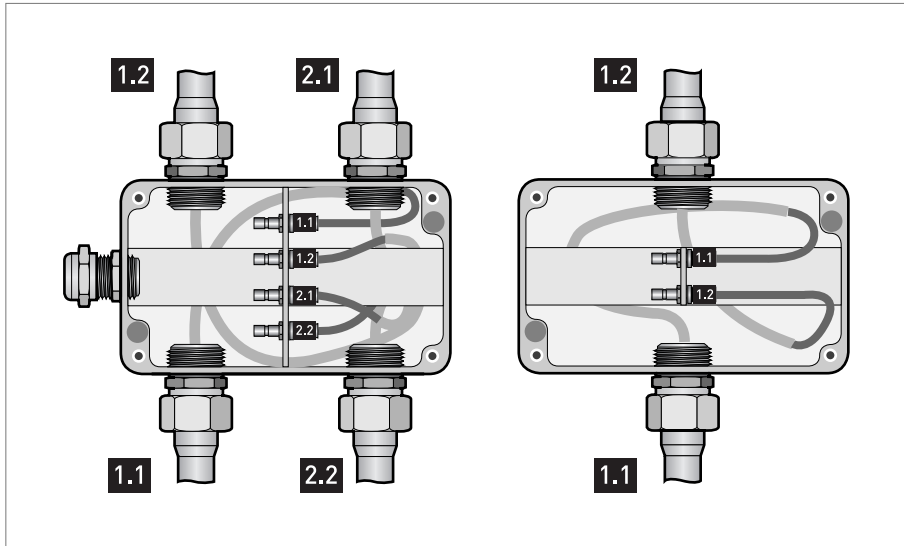

Figure 4-2: Connection of the sensor cables for dual beam (left) and single beam (right) building construction (sensor side)

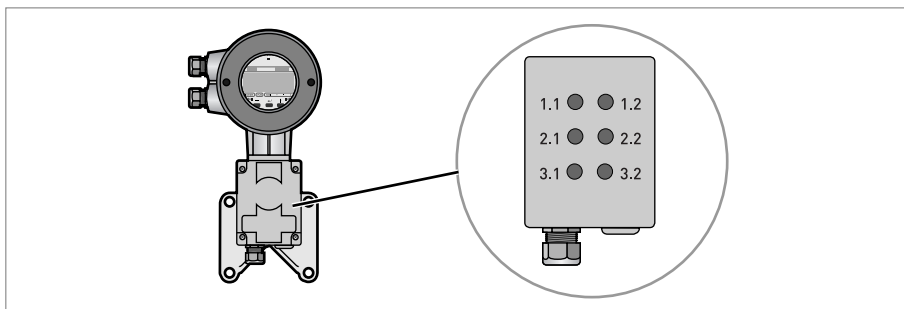

Figure 4-3: Connection of the sensor cables, converter side

4.4 Electrical connections of the signal inputs and outputs



CAUTION!

For wiring of the signal inputs and outputs it is advised to use unshielded twisted pairs.



CAUTION!

Please observe instrument polarity: current (I) is always flowing towards I, C, P, A1, A2 terminals (current sink).

The signal inputs and outputs terminals are located in the converter terminal box. It is accessible after removing the rear (blind) cover of the converter. There are versions for non Ex and for Ex applications.

4.4.1 Non Ex versions

Non Ex standard version

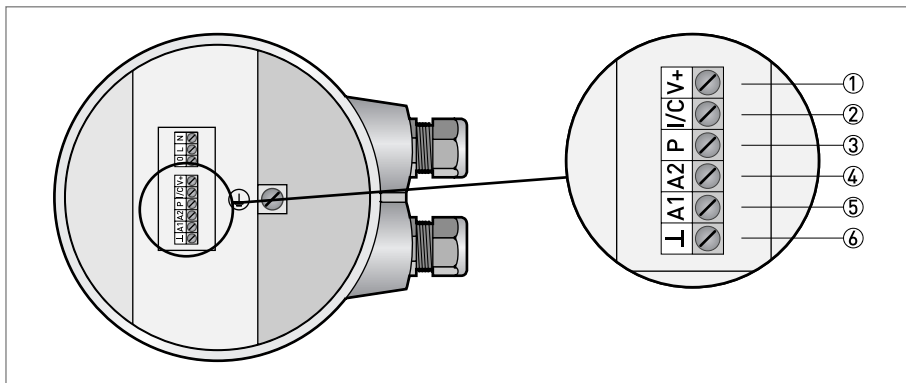

Figure 4-4: Terminals for standard instrument.

Terminal	Function	Specification
①	DC power supply from converter for active wiring of inputs and outputs.	22 VDC at full load, 24 VDC maximum, I ≤ 100 mA.
②	Combined current output (I) and digital input (C). Current output (I) includes HART®-Communication.	Current output (I): I ≤ 22 mA, R _{load} ≤ 680 Ω, U _{max} = 15 VDC. Digital input (C): low = 0...5 VDC, high = 15...32 VDC (will be switched off when current output activated).
③	Pulse / frequency output.	I _{max} = 150 mA, U _{max} = 32 VDC / 24 VAC, maximal frequency = 2 kHz.
④	Analog input 2, for temperature or pressure measurement.	0(4)...20 mA, R _i = 58,2 Ω, fuse = 50 mA.
⑤	Analog input 1, for temperature measurement.	0(4)...20 mA, R _i = 58,2 Ω, fuse = 50 mA.
⑥	Common ground	-



CAUTION!

Never use the active and passive mode at the same terminal simultaneously.

If HART®-Communication is used, do not connect the pulse/frequency output P in active mode.



INFORMATION!

The electrical input and output signals can be connected either in active or in passive mode. In active mode DC supply voltage is provided from the terminal V+. In passive mode supply voltage is provided from an external source.

Non Ex version with Profibus PA

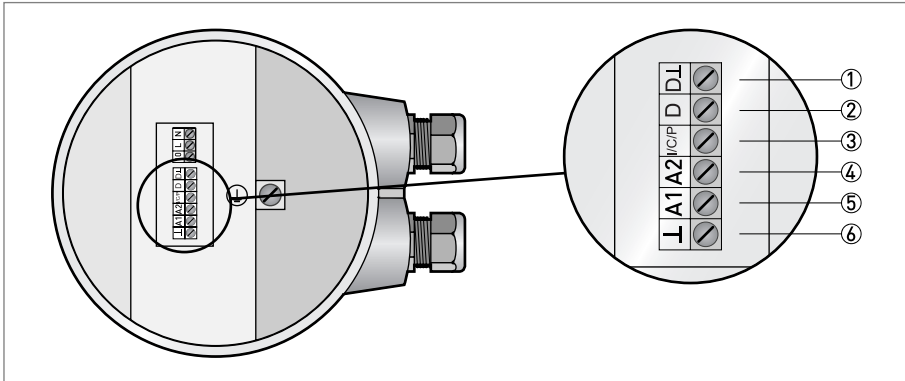

Figure 4-5: Terminals for instrument with Profibus PA (non Ex).

Terminal	Function	Specification
①	Communication connection -	For Fieldbus communication
②	Communication connection +	For Fieldbus communication
③	Combined current output (I), digital input (C) and Pulse / frequency output. Current output (I) includes HART®-Communication.	Current output (I): $I \leq 22 \text{ mA}$, $R_{\text{load}} \leq 680 \Omega$, $U_{\text{max}} = 15 \text{ VDC}$. Digital input (C): low = 0...5 VDC, high = 15...32 VDC (will be switched off when current output activated). Pulse output: $I_{\text{max}} = 150 \text{ mA}$, $U_{\text{max}} = 32 \text{ VDC} / 24 \text{ VAC}$, maximal frequency = 2 kHz.
④	Analog input 2, for temperature or pressure measurement.	0(4)...20 mA, $R_i = 58,2 \Omega$, fuse = 50 mA.
⑤	Analog input 1, for temperature measurement.	0(4)...20 mA, $R_i = 58,2 \Omega$, fuse = 50 mA.
⑥	Common ground	

Non Ex HiPower version

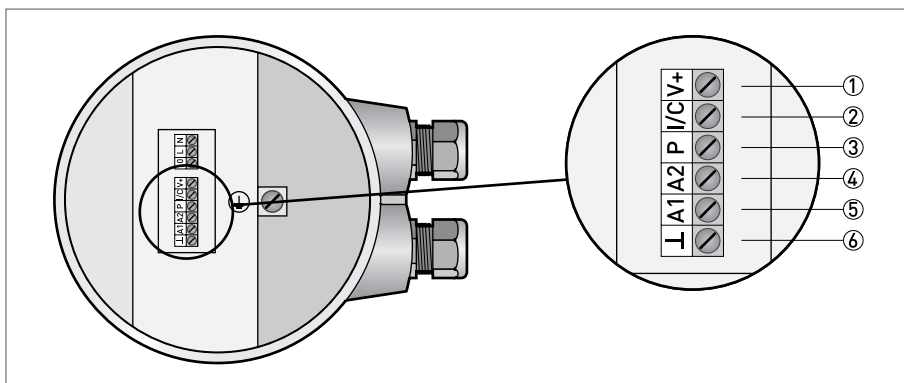

Figure 4-6: Terminals for non Ex HiPower instrument.

Terminal	Function	Specification
①	DC power supply from converter for active wiring of inputs and outputs.	22 VDC at full load, 24 VDC maximum, $I \leq 100 \text{ mA}$.
②	Combined current output (I) and digital input (C). Current output (I) includes HART [®] -Communication.	Current output (I): $I \leq 22 \text{ mA}$, $R_{\text{load}} \leq 680 \Omega$, $U_{\text{max}} = 15 \text{ VDC}$. Digital input (C): low = 0...5 VDC, high = 15...32 VDC (will be switched off when current output activated).
③	Pulse / frequency output.	$I_{\text{max}} = 150 \text{ mA}$, $U_{\text{max}} = 32 \text{ VDC} / 24 \text{ VAC}$, maximal frequency = 2 kHz.
④	Analog input 2, for temperature or pressure measurement.	0(4)...20 mA, $R_i = 58,2 \Omega$, fuse = 50 mA.
⑤	Analog input 1, for temperature measurement.	0(4)...20 mA, $R_i = 58,2 \Omega$, fuse = 50 mA.
⑥	Common ground	-

4.4.2 Ex versions



WARNING!

The electrical input and output signals must be connected in passive mode. The supply voltage must be provided from an external source.

Ex standard version

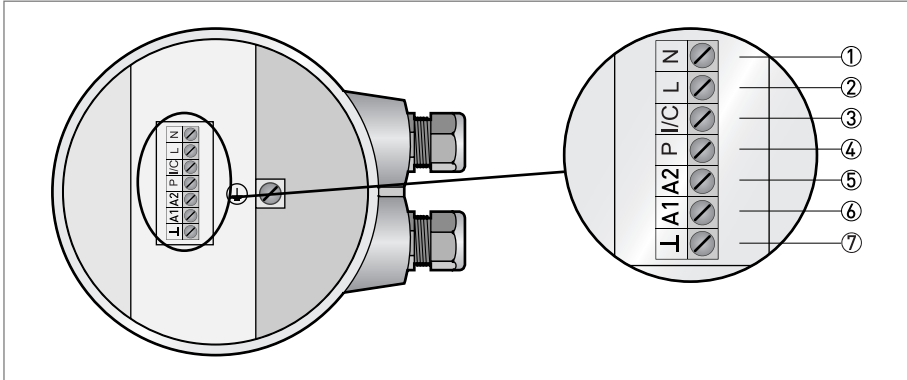

Figure 4-7: Terminals for Ex standard instrument

Terminal	Function	Specification
①	Neutral mains power supply	100...240 VAC, 24 VAC or 24 VDC
②	Live mains power supply	100...240 VAC, 24 VAC or 24 VDC
③	Combined current output (I) and digital input (C). Current output (I) includes HART®-Communication.	Current output (I): $I \leq 22 \text{ mA}$, $R_{\text{load}} \leq 680 \Omega$, $U_{\text{max}} = 15 \text{ VDC}$. Digital input (C): low = 0...5 VDC, high = 15...32 VDC (will be switched off when current output activated).
④	Pulse / frequency output	$I_{\text{max}} = 150 \text{ mA}$, $U_{\text{max}} = 32 \text{ VDC} / 24 \text{ VAC}$, maximal frequency = 2 kHz.
⑤	Analog input 2, for temperature or pressure measurement.	0(4)...20 mA, $R_i = 58,2 \Omega$, fuse = 50 mA.
⑥	Analog input 1, for temperature measurement.	0(4)...20 mA, $R_i = 58,2 \Omega$, fuse = 50 mA.
⑦	Common ground	

Ex NAMUR version

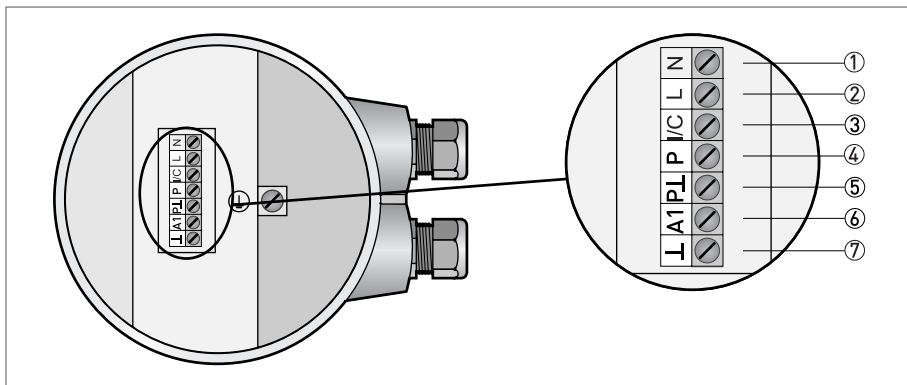

Figure 4-8: Terminals for Ex instrument with NAMUR

Terminal	Function	Specification
①	Neutral mains power supply	100...240 VAC, 24 VAC or 24 VDC
②	Live mains power supply	100...240 VAC, 24 VAC or 24 VDC
③	Combined current output (I) and digital input (C). Current output (I) includes HART®-Communication.	Current output (I): $I \leq 22 \text{ mA}$, $R_{\text{load}} \leq 680 \Omega$, $U_{\text{max}} = 15 \text{ VDC}$. Digital input (C): low = 0...5 VDC, high = 15...32 VDC (will be switched off when current output activated).
④	Pulse / frequency output	$I_{\text{max}} = 150 \text{ mA}$, $U_{\text{max}} = 32 \text{ VDC} / 24 \text{ VAC}$, maximal frequency = 2 kHz.
⑤	Ground for pulse output	
⑥	Analog input 1, for temperature measurement.	0(4)...20 mA, $R_i = 58,2 \Omega$, fuse = 50 mA.
⑦	Common ground	

**INFORMATION!**

The current output of the UFC 030 F-Ex can be set according to NAMUR NE43. The current output will go either to 3.6 or 21.5 mA in case of failure indication.

The following Ex-i Modis versions have two Modis modules, providing intrinsically safe input / output circuits. Modis versions don't have analogue inputs A1 / A2.

Ex-i (Modis) version

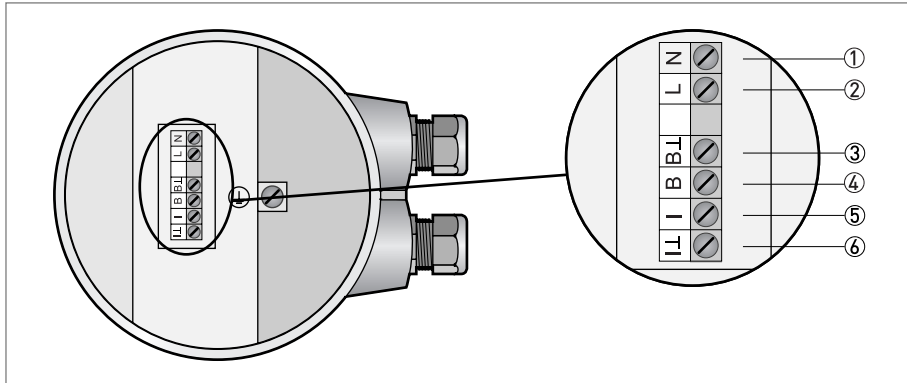

Figure 4-9: Terminals for instrument with Ex-i (Modis)

Terminal	Function	Specification
①	Neutral mains power supply	100...240 VAC, 24 VAC or 24 VDC
②	Live mains power supply	100...240 VAC, 24 VAC or 24 VDC
③	Ground for pulse, frequency or status output	
④	Pulse, frequency or status output	$I_{max} = 150 \text{ mA}$, $U_{max} = 32 \text{ VDC} / 24 \text{ VAC}$, maximal frequency = 2 kHz.
⑤	Current output	Current output (I): $I \leq 22 \text{ mA}$, $R_{load} \leq 680 \Omega$, $U_{max} = 15 \text{ VDC}$.
⑥	Ground for current output	

Ex-i (Modis) version with Profibus PA

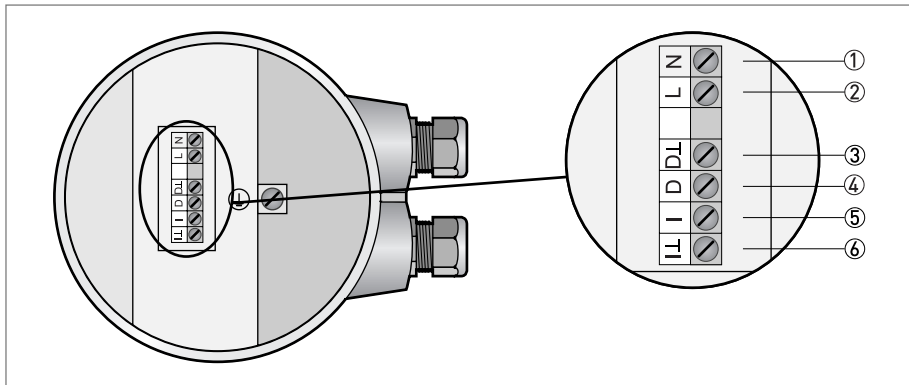

Figure 4-10: Terminals for Ex-i (Modis) version with Profibus PA

Terminal	Function	Specification
①	Neutral mains power supply	100...240 VAC, 24 VAC or 24 VDC
②	Live mains power supply	100...240 VAC, 24 VAC or 24 VDC
③	Profibus communication -	
④	Profibus communication +	
⑤	Current output	Current output (I): $I \leq 22 \text{ mA}$, $R_{\text{load}} \leq 680 \Omega$, $U_{\text{max}} = 15 \text{ VDC}$.
⑥	Ground for current output	

4.5 Connection diagram examples



INFORMATION!

The connection diagrams on the next pages are valid for most versions. However, not all versions have the same connection possibilities. Versions that don't have the V+ terminal (for instance Ex versions) can only be connected in a passive way, e.g. by using an external power supply.

4.5.1 Current output

Current output active

- V+: 22 VDC at full load, 24 VDC maximum, $I \leq 100 \text{ mA}$
- $R_L \leq 680 \Omega$
- $I < 22 \text{ mA}$
- $U_{\text{max}} = 15 \text{ VDC}$

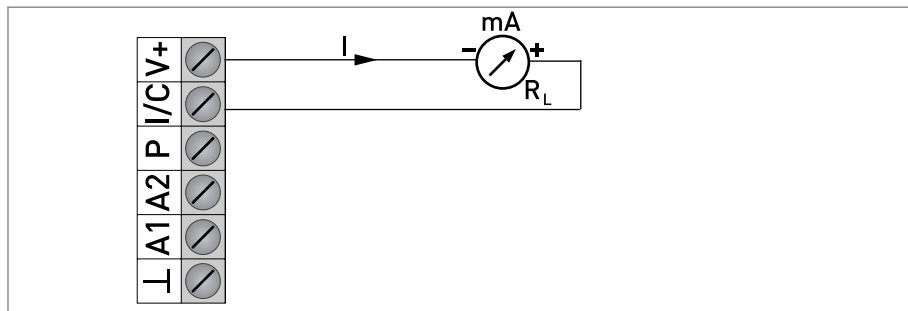

Figure 4-11: Current output (active)

Current output passive

- $U_{\text{ext}} = 15 \dots 24 \text{ VDC}$
(For Ex-i modis versions: $U_{\text{ext}} = 8,1 \dots 30 \text{ VDC}$)
- $I \geq 22 \text{ mA}$ (for supply)
- For Ex-i modis versions: $I = 4 \dots 20 \text{ mA}$
- For Ex-i modis versions: $R_L \leq (U_{\text{ext}} - 8) / 0,022$

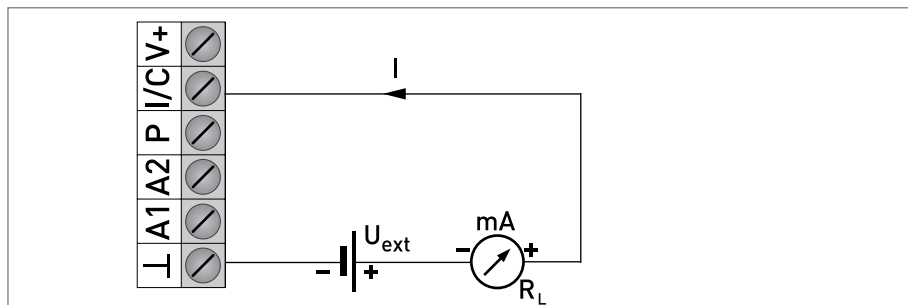

Figure 4-12: Current output (passive)



INFORMATION!

Ex-i modis versions do not have an "I/C" terminal. Use the "I" terminal instead.

4.5.2 Pulse output

Pulse output active

- V_+ : 22 VDC at full load, 24 VDC maximum, $I \leq 100$ mA
- $R_i \geq 470 \Omega$
- frequency ≤ 2 kHz

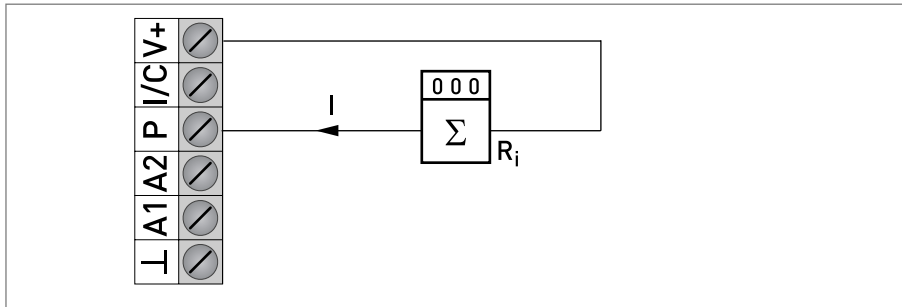

Figure 4-13: Pulse output (active)

Pulse output passive

- $U_{\text{ext}} \leq 32$ VDC or $U \leq 24$ VAC
(For Ex-i modis versions: $U_{\text{ext}} = 6 \dots 30$ VDC)
- $I \leq 150$ mA
(For Ex-i modis versions: $I \leq 110$ mA)
- $R_i \geq 470 \Omega$
- frequency ≤ 2 kHz

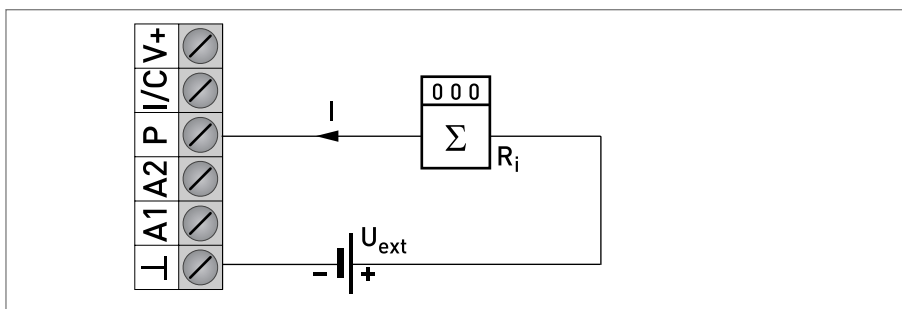

Figure 4-14: Pulse output (passive)

**INFORMATION!**

Ex-i modis versions have different terminal codings.

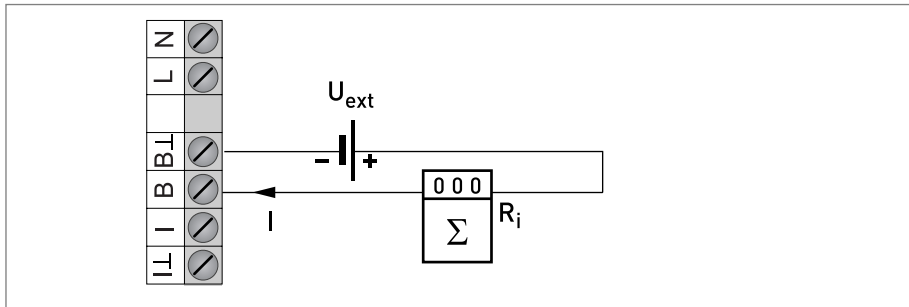

Figure 4-15: Pulse output (passive) for Ex-i Modis

4.5.3 Digital input



INFORMATION!

The digital input will be switched off when the current output is activated.

Digital input active

- V+: 22 VDC at full load; 24 VDC maximum, $I \leq 100 \text{ mA}$
- Low = 0...5 VDC
- High = 15...32 VDC

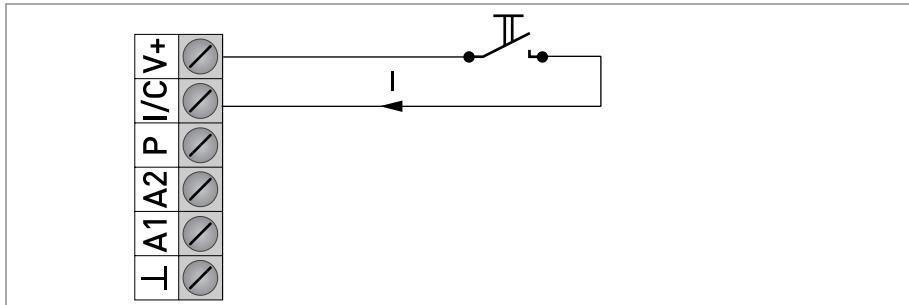

Figure 4-16: Digital input (active)

Digital input passive

- $U_{ext} = 15...30 \text{ VDC}$
- $I \geq 1.5 \text{ mA}$
- Low = 0...5 VDC
- High = 15...32 VDC

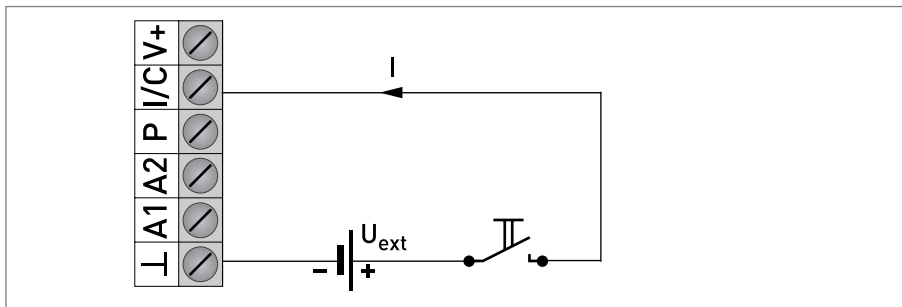

Figure 4-17: Digital input (passive)

4.5.4 Analog input

Analog input

- 0 (4)...20 mA
- $R_i = 58.2 \Omega$
- Fuse 50 mA

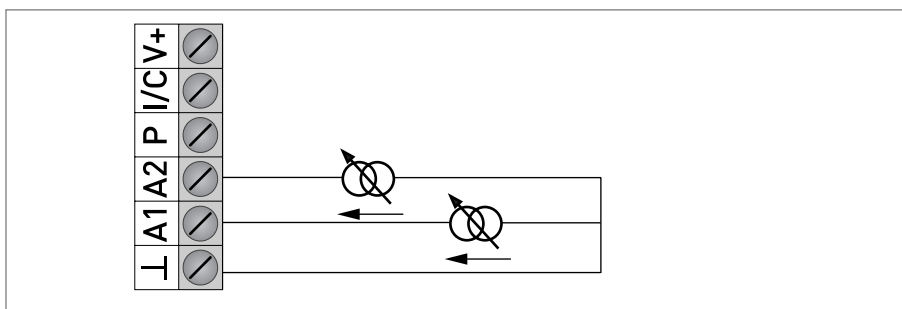

Figure 4-18: Analog input

5.1 Start-up procedure



DANGER!

Hazardous voltages are present within this product during normal operation. Do not operate it with the covers removed!

When powered, "start-up" is shown at the display for a short time. After that the normal measuring mode starts.



INFORMATION!

The flowmeter is programmed at the factory according to your order. No changes are necessary.

6.1 Signal converter: front panel and operating keys

The front panel and its operating keys are accessible after removing the front cover of the electronics section (use the special wrench for it). If it is not allowed to open the housing, for instance in hazardous areas, you can program the converter with the magnetic pin.



CAUTION!

When removing the cover, do not damage the screw thread and the gasket, never allow dirt to accumulate and make sure that they are well greased using Teflon. A damaged gasket must be replaced immediately!

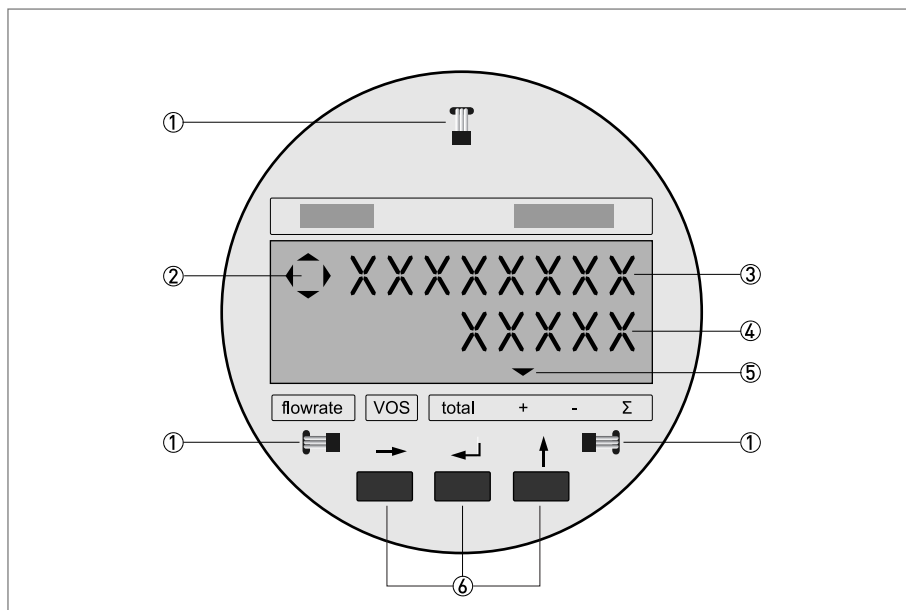

- ① Magnetic sensors to program the signal converter by means of a hand-held bar magnet (optional) without having to remove the front cover (left sensor is equivalent to the "→" key, right sensor to "↑" key and sensor at the top to "←" key).
- ② Compass needles.
- ③ Measured value ("E" stands for "Exponent").
- ④ Unit of measured value.
- ⑤ Indication of actual displayed value.
- ⑥ Operating keys (→, ←, ↑) for programming the signal converter.

Function of operating keys depending on selected mode

Key / symbol	Measuring mode	Menu mode	Data level
→	Go to the parameter setting mode. If access CODE 1 is activated, CODE 1 must be entered first.	Go to the next, lower menu level.	Go to the next character or change line (only when two lines are displayed).
←	Go to the error/totalizer reset mode (via CODE 2).	Return to the previous (higher) menu level or leave the menu mode.	Accept entered value.
↑	Cycle through measured values.	Cycle through menu options within actual menu level.	Raise active digit.

6.2 Available versions



INFORMATION!

The flowmeter is programmed at the factory according to your order. No changes are necessary.

All standard UFC 030 signal converters can be programmed in menu 3.02.01.

1. Standard version

2. CORR T: on-site interchangeable to "standard".

Temperature correction via analogue input 1 (temp range -50... +150°C) ; with this version the outputs are non-Ex-I.

3. CORR T+P: on-site interchangeable to "standard".

Temperature correction via analogue input 1, pressure correction via analogue input 2 (press range 0...100 bar) ; with this version the outputs are Ex-I.

Corrected volume calculation can be done based on temperature correction or temperature - and pressure correction.

The volume correction factor is based on API 2540; chapter 11.1 for the temperature correction and chapter 11.2 for the pressure correction.

For liquid oil products the volume correction factors can be estimated as 0.1% per degree Celsius and 0.01% per bar as a rule of thumb. Therefore for normal industrial processes these corrections are hardly ever applied.

4. HEAT: on-site interchangeable to "standard".

The UFC 030 signal converter is programmed for energy measurement, based on temperature measurements connected via analogue inputs A1 and A2 (temperature range: -50...+150°C); with this version the outputs are non-Ex-I. The following settings are needed:

No. of menu	Display text	Setting/description and functions
3.02.02	INP1 4mA	minimum value of temperature sensor 1 on inlet
3.02.03	INP1 20mA	maximum value of temperature sensor 1 on inlet
3.02.04	INP1 4mA	minimum value of temperature sensor 2 on outlet
3.02.05	INP1 20mA	maximum value of temperature sensor 2 on outlet
3.02.12	full scale	xxx (unit yyy)
3.03.02	function totalizer	select direction
3.03.05	unit for total energy	select unit
3.05.01	function pulse output	CORR FLOW
3.05.10	pulse/unit	select unit

5. BATCH: on-site interchangeable to "standard".

The following settings are needed:

No. of menu	Display text	Setting/description and functions
3.04.01	FUNCTION (current output)	OFF
3.05.01	FUNCTION (pulse output)	BATCH
3.06.01	FUNCTION (digital output)	BATCH
3.02.13	BATCH VOL	xxx(unit yyy)

6. MODIS: setting can not be changed.

The analogue inputs 1 and 2 are not available in this version.

The Ex-I 1 version has a current output (incl. HART®) and a pulse output.

The Ex-I 2 version has a current output (incl. HART®) and a Profibus PA output.

**INFORMATION!**

Depending on the programming of function 3.03.07 the additional or selectable indications can be manually selected by pressing ↑ key, or they are alternating with the display of the measured value(s). The corrected volume flow indication or volume flow totalizer indication is marked with the letter "C" at the left of the display's second (middle) line. The batch totalizer indication is marked with the letter "B".

6.3 Signal converter: menu structure**INFORMATION!**

Since the UFC 030 converter can be equipped with different options, the availability of certain options depends on the function of the converter.

The menu structure consists of five user accessible parts. They are described on the following pages.

Error / totalizer menu

No. of menu	Display text	Setting/description and functions
0.00.01	VIEW ERR	View error messages list.
0.00.02	RST ERR	Reset error messages:
		1) NO RESET: keep error messages list. 2) RESET: reset error messages list.
0.00.03	RST TOTAL	Reset display totalizer(s). Note: all totalizer values are reset!
		Only available when function 3.07.08 is set to YES. Available options:
		1) RESET ALL: reset all totalizer values. 2) NO RESET: keep totalizer values.

**INFORMATION!**

The functions in this menu are a subset of menu 3.00.00. They are selected in this menu as most commonly used functions for a quick installation. Note: parameters set in these functions are automatically set in both menus!

Operation menu

No. of menu	Display text	Setting/description and functions
-------------	--------------	-----------------------------------

1.01.00, FLOW

1.01.01	FULL SCALE	Full-scale value for 100% volume flow rate.
1.01.02	ZERO VALUE	Zero value.
1.01.03	ZERO CAL	Zero calibration.
1.01.04	MASTER TC	Master time constant.
1.01.05	LF CUTOFF	Low-flow cut-off.
1.01.06	CUTOFF ON	Cut-off active.
1.01.07	CUTOFF OFF	Cut-off de-active.

1.02.00, DISPLAY

1.02.01	DISP FLOW	Display of flow.
1.02.02	FUNCT TOT	Function of totalizer.
1.02.03	TOTAL VOL	Display of totalizer.

1.03.00, PULSE OUTP (Pulse output)

1.03.01	PULSE RATE	Pulse frequency value for 100% scale.
1.03.02	PULSE/UNIT	Pulse value per volume flow unit.
1.03.03	PULSE/UNIT	Pulse value per energy unit.

Test functions menu

No. of menu	Display text	Setting/description and functions
This menu is for testing the display, the in- and outputs and for information on hard- and software numbers.		

2.01.00, DISPLAY

2.01.01	DISPLAY	Test display, lights all pixels (end with ← key).
---------	---------	---

2.02.00, OUTPUTS

2.02.01	CURRENT	Test current output (0, 4, 12, 20 and 22 mA).
		Use ↑ key to go to next value. Displayed value directly present at current output. End with ← key.
2.02.02	PULSE	Test pulse/frequency output (1, 10, 100, 1000 and 2000 Hz).
		Use ↑ key to advance. Displayed value directly present at pulse output. End with ← key.

2.03.00, INPUTS

2.03.01	AN INP 1	Test analog input 1. Measure current at analog input 1.
		End with ← key.
2.03.02	AN INP 2	Test analog input 2. Measure current at analog input 2.
		End with ← key.
2.03.03	DIG INPUT	Test digital input. Measure level at digital input.
		End with ← key.
2.03.04	SENSOR	Sensor status: good, open, short

2.04.00, DEV INFO (Device information)

2.04.01	MANUFACT	Display manufacturer.
2.04.02	MODEL NO	Display model number.
2.04.03	SERIAL NO	Display serial number.
2.04.04	UP2 HW NO	Display μ P2 hardware number.
2.04.05	UP2 SW NO	Display μ P2 software number.
2.04.06	FRNT HW NO	Display front end hardware number.
2.04.07	DSP HW NO	Display D.S.P. hardware number.
2.04.08	DSP SW NO	Display D.S.P. software number.
2.04.09	TIME COUNT	Display time counter.

Installation menu

No. of menu	Display text	Setting/description and functions
-------------	--------------	-----------------------------------

3.01.00, FLOW (Volume flow parameters)

3.01.01	FULL SCALE	Full-scale value for 100% volume and flow rate units (see function 1.01.01). The selection of units may be limited to SI units only.
		Available units: m ³ /s, m ³ /min, m ³ /hr, L/s, L/min, L/hr, US.Gal/s, US.Gal/min, US.Gal/hr, bbls/hr, bbls/day or free user configurable unit, set by using function 3.07.05...3.07.07).
3.01.02	ZERO VALUE	Although zero calibrated at the factory the flow sensor might still give an offset flow reading, at "zero" flow in the pipeline. Available settings:
		1) FIXED: factory zero setting. 2) MEASURED: value measured with function 3.01.03 (ZERO CAL).
3.01.03	ZERO CAL	Zero calibration (see function 1.01.03). Note: Carry out only at "zero" flow and with completely filled measuring tube!
		Duration approximately 15s with display indicating "BUSY": 1) STORE NO: preserve old zero value. 2) STORE YES: store new zero value.
3.01.04	MASTER TC	The master time constant apply for the display and the current and pulse outputs. It does not apply for totalisation and for the current output in F/R setting. If required, a different time constant value can be set for the pulse/frequency output under Function 3.05.06.
		Range: 0.02...99.99 s.
3.01.05	LF CUTOFF	Low-flow cut-off for display and outputs.
		1) NO: fixed tripping points (ON = 0.1%, OFF = 0.2%). 2) YES: see function 3.01.06 and 3.01.07.
3.01.06	CUTOFF ON	Cut off "active" value.
		Range: 1 through 19% of Q _{100%} .
3.01.07	CUTOFF OFF	Cut off "de-active" value. Note: value "off" must be greater than value "on"!
		Range: 2 through 20% of Q _{100%} .
3.01.08	METER SIZE	The nominal diameter of the measuring tube. See the flow sensor nameplate. Selection of size from meter size table: 25...3000 mm / 1...120".
3.01.09	GK VALUE	At the factory, each flow sensor is calibrated and supplied with a calibration constant (GK). This constant can be found on the flow sensor nameplate and must equal the value on the flow sensor nameplate.
		Range: 0.02...20.
3.01.10	FLOW DIR	The forward flow direction is indicated with an arrow on the flow sensor. Available settings:
		1) POSITIVE: If the actual flow is in the direction of the arrow then the flow is in the positive direction and the converter will have a positive flow reading. 2) NEGATIVE: reversed reading of the converter, useful when the process flow direction is changed so the flow sensor will not need to be reversed.

No. of menu	Display text	Setting/description and functions
3.01.11	MIN VOS	Minimum velocity of sound (VOS). Value used for I _{0%} or P _{0%} when function "VOS" selected in function 3.04.01 or 3.05.01. Units: m/s or feet/s, range: 0...4999 m/s (0...16.400 feet/s).
3.01.12	MAX VOS	Maximum velocity of sound. Value used for I _{100%} or P _{100%} when function "VOS" selected in function 3.04.01 or 3.05.01. Note: maximum value must be greater than minimum value! Units: m/s or feet/s, range: 1...4999 m/s (0...16.400 feet/s).

3.02.00, VERSION

3.02.01	FUNCTION	Function of converter. This is factory pre-set and can only be changed to standard from any setting: 1) STANDARD. 2) CORR T: temperature correction of the measured flow via analog input 1. 3) CORR T + P: temperature and pressure correction of the measured flow via analog input 1 (pressure) and analog input 2 (temperature). 4) HEAT: reserved for measurement of heat power and heat energy totalisation. 5) BATCH: batch volume. 6) MODIS: Cannot be altered.
3.02.02	INP1 4 mA	4 mA reference for analog input 1, 4 mA temperature reference. Unit: °C or °F, range: -50...+150°C / -58...302°F.
3.02.03	INP1 20 mA	20 mA reference for analog input 1, 20 mA temperature reference. Unit: °C or °F, range: -50...+150°C / -58...302°F.
3.02.04	INP2 4 mA	4 mA reference for analog input 2, 4 mA temperature reference. Unit: °C or °F, range: -50...+150°C / -58...302°F.
3.02.05	INP2 20 mA	20 mA reference for analog input 2, 20 mA temperature reference. Unit: °C or °F, range: -50...+150°C / -58...302°F.
3.02.06	INP2 4 mA	4 mA reference for analog input 2, 4 mA pressure reference. Unit: bar(a) or psi(a), range: 0...100 bar(a).
3.02.07	INP2 20 mA	20 mA reference for analog input 2, 20 mA pressure reference. Unit: bar(a) or psi(a), range: 0...100 bar(a).
3.02.08	K0	Product constant K0. Range: 10 ⁻⁹ ...10 ⁹ .
3.02.09	K1	Product constant K1. Range: 10 ⁻⁹ ...10 ⁹ .
3.02.10	K2	Product constant K2. Range: 10 ⁻⁹ ...10 ⁹ .
3.02.11	DENSITY 15	Product density at T = 15°C / 59°F. Range: 500...2000 kg/m ³ .
3.02.12	FULL SCALE	Heat measurement. Full scale setting and unit for heat power. Available units: GJ/s, GJ/hr, MJ/s, MJ/hr, GCal/s, GCal/hr, MCal/s, MCal/hr.

No. of menu	Display text	Setting/description and functions
3.02.13	BATCH VOL	Batch volume total size and units.
		Available units: m ³ , Liter, US-Gallon, Barrel or user definable unit.
		Range: 0.025...100000 m ³ .

3.03.00, DISPLAY.

3.03.01	DISP FLOW	Display of flow. Available options:
		1) RATE: full-scale units (flow is shown with the unit as set in function 3.01.01).
		2) PERCENT: flow is shown as a percentage (0...100%) of the full scale value.
		3) NO DISPLAY: no flow is shown.
3.03.02	FUNCT TOT	Function of totalizer. Two totalizers (counters) are available. The totalizer values are incremented and stored once a second. The following settings are available:
		1) ACT FLOW: actual flow units, used for counting the total volume in the totalizer (for each direction one totalizer is available, the sum of the two can also be displayed).
		2) CORR FLOW: the corrected flow is used for counting the total volume in the totalizers.
		3) POS BOTH: both the actual and the corrected flow are used for counting the total volume in the totalizers. Note: both are only counted in the positive direction!
3.03.03	DISP TOTAL	Display of totalizer. A totalizer can be selected here for displaying:
		1) TOTAL OFF: both totalizers are switched off, counting stops.
		2) FORWARD: forward volume units.
		3) REVERSE: reverse volume units.
		4) BOTH: both totalizers, alternating.
		5) SUM: sum of both totalizers.
		6) BOTH + SUM: both totalizers und their sums show alternating.
		7) NO DISPLAY: totalizers are not displayed but totalizers count.
3.03.04	TOTAL VOL	Unit for volume totalizer. Note: the maximal value of the totalizer is 99999999 x 10 m ³ and will roll over to 0 at overrun!
		Available units: X10 m ³ , US-Gallon, m ³ , barrel, liter.
3.03.05	TOTAL ENER	Unit for the heat energy totalizer. Note: the maximal value of the totalizer is 99999999 x 10 GJ and will roll over to 0 at overrun!
		Available units: X10 GJ, GJ, MJ, GCal., MCal.
3.03.06	VOS	Unit for velocity of sound. Available options:
		1) NO DISPLAY: no display of the velocity of sound.
		2) m/s, feet/s.
3.03.07	CYCL DISP	If more than one measured value are to be displayed (e.g. flow rate and totalizer), each value can be selected manually by pressing the ↑ key, or the values can be alternately displayed each five seconds by turning the cyclic display function on.
3.03.08	ERROR MSG	Display error messages

No. of menu	Display text	Setting/description and functions
3.03.10	AN INPUT	Enabling or disabling the display of the analog inputs. Note: this function is only available for converter function CORR T and CORR T+P (see function 3.02.01)!
		The display of the values represented by the current signal coming from the temperature and pressure transducers. Available settings:
		1) NO
3.03.11	SIGN LEVEL	This function enables or disables the display of the signal level from the sensors. For each measuring path this level is displayed as a gain value 0...80 dBV at the input amplifier. Available options:
		1) NO
		2) YES

3.04.00, CURR OUTP (Current output)

3.04.01	FUNCTION	The current output can be programmed for the following functions:
		1) OFF: switched off, current output steady at current value for 0 % scale.
		2) ACT FLOW: proportional with the actual volume flow.
		3) CORR FLOW: proportional with the corrected volume flow. Note: this function ist only available if the converter function is set to CORR T or CORR T+P [see function 3.02.01]!
		4) F/R IND: forward/reverse indication of actual flow. 100 pct mA value for forward flow, 0 pct mA value for reverse flow.
		5) VOS: proportional with the velocity of sound (range is defined in function 3.01.11 and 3.01.12).
		6) GAIN: sensor signal gain, range is 0...100 dBV.
		7) AN INP 1: proportional with the signal on analog input 1. Note: this function is only available if the converter function is set to CORR T or CORR T+P!
3.04.02	DIRECTION	Direction of current output, only available when ACT FLOW or CORR FLOW is selected in function 3.04.01. In this case there are the following options:
		1) FORWARD: the current output will only be active when the flow is in the forward flow direction as defined in function 3.01.10.
		2) BOTH: the current output will be active when the flow is in the forward ord reverse flow direction, indicating both in the same range.
		3) F/R SPEC: forward and reverse flow measurement indicated in different range. Use this function to indicate the reverse flow in the range from 0 mA through 0 pct mA. Note: when the flow goes from the forward direction to the negative direction, the current output will pass the "0 pct" mA value down to 0 mA, where it stops!
3.04.03	RANGE	Range of current output (Note: maximum reading is 22 mA!):
		1) OTHER: user defined span.
		2) 0...20/22 mA: 0...100 pct / limit. 3) 4...20/22 mA: 0...100 pct / limit.
3.04.04	0 pct	Setting of mA for 0% of the range.
		Range: 0...16 mA (default: 4 mA).
3.04.05	100 pct	Setting of mA for 100% of the range. Note: value must be at least 4 mA greater than current value for 0% scale!
		Range: 4...20 mA (default: 20 mA).
3.04.06	LIMIT	Limitation of current output. While default is 22 mA it can be switched to 20 mA when safety system reserve higher currents as fault codes.
		Range: 20...22 mA.
3.04.07	ERR INDIC	Only available for NAMUR devices. Options:
		1) I _{ERR} = 3.6 mA.
		2) I _{ERR} = 21.5 mA.

3.05.00, PULSE OUTP (Pulse output)

3.05.01	FUNCTION	Function of pulse output with the following options:
		1) OFF: switched off, contact closed.
		2) ACT FLOW: proportional with the actual volume flow.
		3) CORR FLOW: proportional with the corrected volume flow.
		4) F/R IND: forward/reverse flow indication. Contact closed for forward flow, contact open for reverse flow .
		5) VOS: proportional with the velocity of sound (range defined in function 3.01.11 and 3.01.12).
		6) DIG OUTPUT: digital output.
		7) BATCH OUTP: batch output indication, only available for the batch-version. Contact closes at start of the batch and opens when the batch is reached.
		8) GAIN: gain of sensor amplifier, proportional with the signal level. Range: 0...100 dBV.
		9) AN INP 1: proportional with the signal on analog input 1, only available for the converter functions CORR T and CORR T+P.
		11) AN INP 2: proportional with the signal on analog input 2, only available for the converter functions CORR T and CORR T+P.
3.05.02	DIRECTION	Direction of pulse output, only available when ACT FLOW or CORR FLOW is selected in function 3.05.01.
		1) FORWARD: the pulse output will only be active when the flow is in the forward flow direction as defined in function 3.01.10.
		2) BOTH: the pulse output will be active in both flow directions (forward and reverse), indicating both in the same range.
3.05.03	DIG OUTPUT	Function of digital output, only available when DIG OUTPUT is selected in function 3.05.01. The pulse output now acts as a digital output and can be programmed for the following functions:
		1) PATH ERR: measuring path error indication (contact open).
		2) TOTAL ERR: totalizer error indication (contact open).
		3) ALL ERR: indication of all errors (contact open).
		4) AN INP ERR: analog input error indication (contact open).
		5) OVERRANGE: overrange indication (contact open).
3.05.04	TRIP PNT 1	First trip point.
		Range: 0...120% of $Q_{100\%}$.
3.05.05	TRIP PNT 2	Second trip point.
		Range: 0...120% of $Q_{100\%}$.
3.05.06	TIME CONST	Time constant of pulse output (Note: the time constant setting only applies to actual flow and corrected flow!):
		1) 25 ms (lowest value).
		2) MASTER TC: time constant has the value set in function 3.01.04.

3.05.07	OUTPUT	Unit of pulse output:
		<p>1) PULSE RATE (frequency): pulses per unit time, setting by entering a frequency at 100% volume flow rate.</p> <p>2) PULSE/UNIT (totalizer pulse output): pulses per unit volume, setting by entering a value for the number of pulses for each volume or energy unit. Each pulse has a fixed volume (i.e. 1 pulse per 0.1 liter). This is the best method of remote totalizing, as pulses simply need to be counted.</p>
3.05.08	PULSE RATE	<p>Pulse rate (frequency) value for 100% scale. If function 3.05.07 is set to PULSE RATE, the following units can be chosen using this function: pulse/s, pulse/hr, pulse/min.</p> <p>Range: 10 pulses/h...2000 pulses/s, default setting: 1000 Hz.</p>
		<p>Pulse value per volume unit for totalisation. Note: Check that the maximum flow span will not cause the number of pulses generated per second to exceed the maximum of 2000 Hz!</p> <p>If function 3.05.07 is set to PULSE/UNIT, the unit and number of pulses per unit can be set for the flow measurement using this function. Available options: pulse/m³, pulse/l, pulse/US-Gallon, pulse/bbl, free user definable unit.</p> <p>Default setting: 1, maximum number of pulses per unit: 7870000.</p>
3.05.09	PULSE/UNIT	<p>Pulse value per heat energy unit for totalisation. If function 3.05.07 is set to PULSE/UNIT, the unit and number of pulses per unit can be set for the heat power measurement using this function. Available options: pulse/MJ, pulse/GCal, pulse/MCal, pulse/GJ.</p> <p>Default setting: 1, maximum number of pulses per unit: 1000000.</p>
		<p>For frequencies ≤10 Hz the following pulse widths can be applied:</p> <p>1) 25 ms for P_{100%} < 10 Hz.</p> <p>2) 50 ms for P_{100%} < 10 Hz.</p> <p>3) 100 ms for P_{100%} < 5 Hz.</p> <p>4) 200 ms for P_{100%} < 2.5 Hz.</p> <p>5) 500 ms for P_{100%} < 1 Hz.</p> <p>For frequencies 10...1000 Hz: 50% duty cycle, 1000...2000 Hz: 70/30% duty cycle (Note: pulse width may vary 5 ms, pulse period may vary 25 ms!)</p>
3.05.10	PULSE/UNIT	<p>For frequencies ≤10 Hz the following pulse widths can be applied:</p> <p>1) 25 ms for P_{100%} < 10 Hz.</p> <p>2) 50 ms for P_{100%} < 10 Hz.</p> <p>3) 100 ms for P_{100%} < 5 Hz.</p> <p>4) 200 ms for P_{100%} < 2.5 Hz.</p> <p>5) 500 ms for P_{100%} < 1 Hz.</p> <p>For frequencies 10...1000 Hz: 50% duty cycle, 1000...2000 Hz: 70/30% duty cycle (Note: pulse width may vary 5 ms, pulse period may vary 25 ms!)</p>
		<p>For frequencies ≤10 Hz the following pulse widths can be applied:</p> <p>1) 25 ms for P_{100%} < 10 Hz.</p> <p>2) 50 ms for P_{100%} < 10 Hz.</p> <p>3) 100 ms for P_{100%} < 5 Hz.</p> <p>4) 200 ms for P_{100%} < 2.5 Hz.</p> <p>5) 500 ms for P_{100%} < 1 Hz.</p> <p>For frequencies 10...1000 Hz: 50% duty cycle, 1000...2000 Hz: 70/30% duty cycle (Note: pulse width may vary 5 ms, pulse period may vary 25 ms!)</p>
3.05.11	PULS WIDTH	<p>For frequencies ≤10 Hz the following pulse widths can be applied:</p> <p>1) 25 ms for P_{100%} < 10 Hz.</p> <p>2) 50 ms for P_{100%} < 10 Hz.</p> <p>3) 100 ms for P_{100%} < 5 Hz.</p> <p>4) 200 ms for P_{100%} < 2.5 Hz.</p> <p>5) 500 ms for P_{100%} < 1 Hz.</p> <p>For frequencies 10...1000 Hz: 50% duty cycle, 1000...2000 Hz: 70/30% duty cycle (Note: pulse width may vary 5 ms, pulse period may vary 25 ms!)</p>
		<p>For frequencies ≤10 Hz the following pulse widths can be applied:</p> <p>1) 25 ms for P_{100%} < 10 Hz.</p> <p>2) 50 ms for P_{100%} < 10 Hz.</p> <p>3) 100 ms for P_{100%} < 5 Hz.</p> <p>4) 200 ms for P_{100%} < 2.5 Hz.</p> <p>5) 500 ms for P_{100%} < 1 Hz.</p> <p>For frequencies 10...1000 Hz: 50% duty cycle, 1000...2000 Hz: 70/30% duty cycle (Note: pulse width may vary 5 ms, pulse period may vary 25 ms!)</p>

3.06.00, DIG INPUT (Digital input)

3.06.01	FUNCTION	Function of digital input. The digital input terminal is the same as the current output terminal. Therefore, when a digital input function is selected, the function of the current output needs to be set to OFF and the current output range has to be set to 0...20 mA. The following options are available for the digital input:
		1) OFF: switched off, no function.
		2) RST TOTAL: reset display totalizer(s), independent of the programming of function 3.07.08.
		3) RST ERROR: reset error messages.
		4) FORCE ZERO: force display and outputs to their "zero" values.
		5) BATCH: start (input high) or stop (input low) a batch, only available for the batch-version.

3.07.00, USER DATA

3.07.01	LANGUAGE	Language for display texts:
		1) GB/USA: English.
		2) D: German. 3) F: French.
3.07.02	ENTRY CODE	Entry code for setting mode:
		1) NO: entry with → key only. 2) YES: entry with → key and code 1, factory set on 9 x key.
3.07.03	CODE 1	Press any 9-keystroke combination and then press the same combination again. Each keystroke is acknowledged by "?" in the display. If both combinations are equal, "CODE OK" appears and the new code can be stored. Otherwise "WRONG CODE" appears and the desired code has to be entered again.
3.07.04	LOCATION	Tag name setting. Free settable tag for identification, maximum 10 characters.
		Characters assignable to each place: A...Z, blank character, 0...9.
		Factory setting: KROHNE.
3.07.05	UNIT TEXT	Text for user-defined unit. Definition: volume/time.
		Characters assignable to each place: A...Z, blank character, 0...9. Note: fraction bar "/" in 5th place is unalterable!
		Factory setting: XXXX/YYYY.
3.07.06	UNIT VOL	User-defined unit volume. Quantity of user-defined volume per m ³ .
		Range: 10 ⁻⁵ ...10 ⁷ , factory setting: 1.
3.07.07	UNIT TIME	User-defined unit time. Amount of user-defined time in seconds.
		Range: 10 ⁻⁵ ...10 ⁷ , factory setting: 1.
3.07.08	RST ENABLE	Enable the reset of the display totalizer(s). Note: this function doesn't affect the ability to reset the display totalizer(s) using the digital input! Available options:
		1) NO: totalizer reset disabled.
		2) YES: totalizer reset enabled.
3.07.09	ERR LIMIT	Error limit in % of measured value for plausibility filter on the sensor paths.
3.07.10	CNT DECR	Counter decrement setting for plausibility filter.
3.07.11	CNT LIMIT	Counter limit for plausibility filter. When "0" is set, the plausibility filter will become inactive.
		Range: 0...1000, factory setting: 0.

3.09.00, COMMUNICATION

3.09.01	PROTOCOL	Communication protocol:
		1) OFF: no communication.
		2) HART: HART® (standard available).
		3) PROFIB PA: PROFIBUS PA (optional available).
3.09.02	HART ADDR	HART® address.
		Range: 00...16.
3.09.03	PP/FF ADDR	PROFIBUS PA address.
		Range: 000...126.



INFORMATION!

In the next part, multiple error messages are shown. Details about the specific functions are described earlier in the "Installation menu".

Parameter error menu

No. of menu	Display text	Setting/description and functions
-------------	--------------	-----------------------------------

4.01.00, FLOW VELOC

Volume flow velocity (v) value incorrect. The flow speed is calculated from the full scale volume flow and the meter size. Note: ensure condition $0.5 \text{ m/s} \leq v \leq 20 \text{ m/s}$ ($1.64 \text{ feet/s} \leq 65.62 \text{ feet/s}$) is met!		
4.01.01	FULL SCALE	Full-scale value for 100% volume flow rate.
4.01.02	METER SIZE	Meter size.

4.02.00, CURR OUTP (Current output)

Current output range incorrect. Setting for 100% is compared with setting for 0%. Note: ensure condition $100 \text{ pct} - 0 \text{ pct} \geq 4 \text{ mA}$ is met!		
4.02.01	RANGE	Range of current output.
4.02.02	0 pct	Current value for 0% scale.
4.02.03	100 pct	Current value for 100% scale.

4.03.00, LF CUTOFF (Low-flow cut-off)

Low-flow cut-off range incorrect. If low flow cut-off is set to "on", the value for CUTOFF-OFF is compared with the value of CUTOFF-ON on. Note: ensure condition $\text{CUTOFF-OFF} - \text{CUTOFF-ON} \geq 1\%$ is met!		
4.03.01	LF CUTOFF	Low-flow cut-off.
4.03.02	CUTOFF ON	Cutoff "on" value.
4.03.03	CUTOFF OFF	Cutoff "off" value.

4.04.00, ENERGY

Full scale value for heat energy rate (E) incorrect. The fullscale value is compared with the maximum value that can be measured and should meet the condition $E_{\text{max}} < E_{\text{fullscale}} < E_{\text{max}}/1000$. Note: the maximum value that can be measured is at maximum flow and 200°C temperature difference!		
4.04.01	HEAT FS	Full-scale value for 100% heat energy rate.

4.05.00, PULSE/VOS (Pulse/Velocity of sound)

Unit of pulse output for velocity of sound function incorrect. Note: ensure that "PULSE RATE" is selected for "VOS"!		
--	--	--

No. of menu	Display text	Setting/description and functions
4.05.01	PULS FUNCT	Function of pulse output.
4.05.02	PULSE OUTP	Unit of pulse output.

4.06.00, VOS (Velocity of sound)

Velocity of sound range incorrect. Note: ensure condition $\text{MAX VOS} - \text{MIN VOS} \geq 1 \text{ m/s}$ (3.28 feet/s) is met!		
4.06.01	MIN VOS	Minimum velocity of sound.
4.06.02	MAX VOS	Maximum velocity of sound.

4.07.00, PULSE OUTP (Pulse output)

Pulse output frequency value (f) incorrect. The maximum frequency is calculated from the PULSE/UNIT setting and the maximum value of the measured value. Note: ensure condition $1 \text{ pulse/hr} \leq f \leq 2000 \text{ pulse/s}$ is met!		
4.07.01	PULSE/UNIT	Pulse value for volume flow rate unit.
4.07.02	PULSE/UNIT	Pulse value for heat power rate unit.

4.08.00, PULS WIDTH

Pulse output pulse width incorrect. Note: ensure condition $\text{pulse width} \leq 0.5 \times \text{pulse period time}$ is met!		
4.08.01	PULS WIDTH	Pulse width for frequencies $\leq 10 \text{ Hz}$.

4.09.00, HART

Current output range for HART [®] incorrect. If HART [®] is activated, the minimum possible current should be 4 mA. Note: ensure condition $\text{CURR 0 pct} \geq 4 \text{ mA}$ is met!		
4.09.01	CURR RANGE	Range of current output.
4.09.02	CURR = PCT	Current value for 0% scale.

4.10.00, INP/OUTP (Input/Output)

The digital input (C) and current output (I) are not allowed to be switched on simultaneously. If the Profibus option is activated, only one of the following input/output functions can be used: digital input (C), current output (I), pulse output (P). The current output is deactivated by setting the function of current output to "off" and setting the range of current output to 0...20 mA.		
4.10.01	INP FUNCT	Function of digital input.
4.10.02	CURR FUNCT	Function of current output.
4.10.03	CURR RANGE	Range of current output.
4.10.04	PULS FUNCT	Range of pulse output.

4.13.00, EPROM

EPROM checksum error. Resetting device is necessary.		
--	--	--

6.4 Important menu functions in detail



INFORMATION!

Since the UFC 030 converter can be equipped with different options, the availability of certain options depends on the function of the converter.

In this chapter the different functions of the menu structure are described in more depth.

6.4.1 Error/totalizer (Menu 0.00.00)

This menu is accessible from the measuring mode by pressing the \leftarrow key to enter "CODE 2" and afterwards pressing the key \uparrow and then \rightarrow .



INFORMATION!

Only when function 3.03.08 is set to YES, errors occurring during process flow measurement are represented with flashing display lines and/or a compass field!

Depending on the programming of function 3.03.07, the error messages alternate with the display of the measured value(s) every five seconds or they can be manually selected by pressing the \uparrow key.

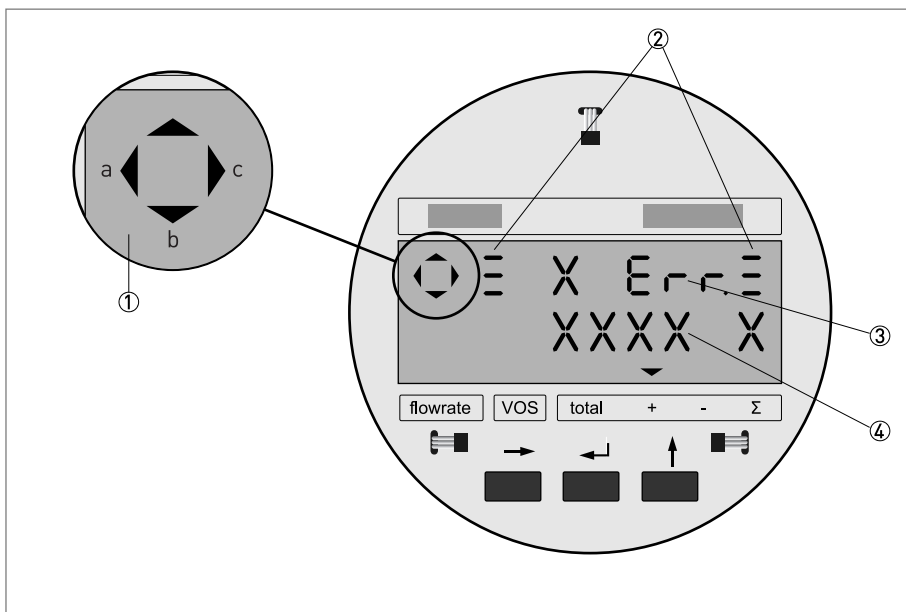

- ① Compass needle, indicating measuring path error(s): depending on the version of the sensor triangle a appears when there is no measured value from path 2 and triangle b from path 1; triangle c appears when there is too much noise on the measuring path(s) for proper measurement.
- ② Flashing bar, indicating "new" errors, i.e. not yet acknowledged.
- ③ Flashing line with description of error message(s).
- ④ Flashing line with number of errors that have occurred.

The following list gives an alphabetical overview of error messages that can occur during process flow measurement and what to do:

Error message	Description of error message	What to do
ADC AN INP	Analog input internal error (A1 or A2).	Switch off the flowmeter and switch it on again. If the error still exists, contact your local representative.
COMMUNIC	Communication device internal error.	Reset the error and wait for one minute. If the error reappears, contact your local representative.
CURR > MAX	Current output overflow (> 22 mA).	Check flow velocity.
DSP	Digital signal processor (DSP) internal error.	Only checked at power-up. Switch off the flowmeter and switch it on again. If the error still exists, contact your local representative.
EE MENU	Menu parameters corrupted.	Contact your local representative.
EE SERVICE	Service parameters internal error.	Contact your local representative.
EMPTY PIPE	Measuring tube not completely filled, flowreading to 0, error on all paths.	Fill measuring tube completely.
FLOW > MAX	Measuring range overflow (flow > 2 × Q _{max}).	Check flow velocity.
FRONT END	Front end internal error.	Only checked at power-up. Switch off the flowmeter and switch it on again. If the error still exists, contact your local representative.
INP1 < MIN	Analog input 1 too low (<3.6 mA).	Check analog input 1 connection.
INP1 > MAX	Analog input 2 too high (>22 mA).	Reduce analog input 1 current.
INP2 < MIN	Analog input 2 too low (<3.6 mA).	Check analog input 2 connection.
INP2 > MAX	Analog input 2 too high (>22 mA).	Reduce analog input 2 current.
RESTART	Flow meter restarted.	Reset errors.
UNRELIABLE	Flow data disturbed, same as triangle 4 in the compass field.	Check flow conditions.
OPEN CIRC	Sensor X not connected or damaged (combined with message SENSOR X).	Check connection of sensor X. For sensor numbering see description of test function 2.03.04.
PATH 1	Measuring path 1 error.	Check flow conditions.
PATH 2	Measuring path 2 error.	Check flow conditions.
PULS > MAX	Pulse output overflow (>120%).	Check flow velocity.
SENSOR X	Sensor X error (combined with OPEN CIRC or SHORT CIRC message).	Check connection sensor X.
SHORT CIRC	Sensor X short-circuited (combined with message SENSOR X).	Check connection sensor X.
TIME/DATE	Real time clock internal error.	Not available, reserved for future use.
TOT > DISP	Totalizer out of display range (maximum: eight characters).	Reset totalizer or change totalizer unit.
TOT CHKSUM	Totalizer corrupted.	Reset totalizer.
UP2	μP2 internal error.	Contact your local representative.

6.4.2 View error messages / reset error messages (menu 0.00.01 and 0.00.02)

All occurred error messages are stored in an error messages list and can be viewed using function 0.00.01. The messages are kept in this list until the cause of the error(s) has been removed and the error messages have been reset using function 0.00.02.

Errors that have been reset, but whose cause has not been removed, are kept in the list but are displayed without bar. This allows identification of previously acknowledged and unacknowledged errors.

6.4.3 Full-scale value for 100% volume and flow rate units (menu 3.01.01)

The measuring range depends on the diameter (DN) of the pipe and the volume flow velocity:

	$v_{min} = 0.5 \text{ m/s} / 1.64 \text{ ft/s}$	$v_{max} = 20 \text{ m/s} / 65.62 \text{ ft/s}$
$Q_{min} \text{ (m}^3\text{/h)}$	$0.9 \times \text{DN}^2$	-
$Q_{max} \text{ (m}^3\text{/h)}$	-	$31.25 \times \text{DN}^2$
$Q_{min} \text{ (US.Gal/min)}$	$3.9 \times \text{DN}^2$	-
$Q_{max} \text{ (US.Gal/min)}$	-	$138 \times \text{DN}^2$

6.4.4 Low-flow cut-off, cut-off "on"/"off" value (menu 3.01.05...3.01.07)

Due to the extreme low flow sensitivity of the UFM 3030, it will detect the slightest movement of fluid, even at zero flow. To avoid these measurements causing outputs and totalizer changes, the low-flow cut-off can be used to force reading to zero. These are set as a percentage of full scale, as configured in function 1.01.01 or 3.01.01:

- When the flow rate decreases below the "on" value, the display and outputs are set to their "zero" values.
- When the flow increases above the "off" value, measurements are resumed.



INFORMATION!

The "off" value must be larger than the "on" value by at least 1%.

With function 3.01.05 set to NO, factory settings are used for the "on" and "off" values.

6.4.5 Direction of current output (menu 3.04.02)



INFORMATION!

This function is only available when *ACT FLOW* or *CORR FLOW* is selected in function 3.04.01. When *VOS* or *GAIN* is set, only the forward characteristic applies.

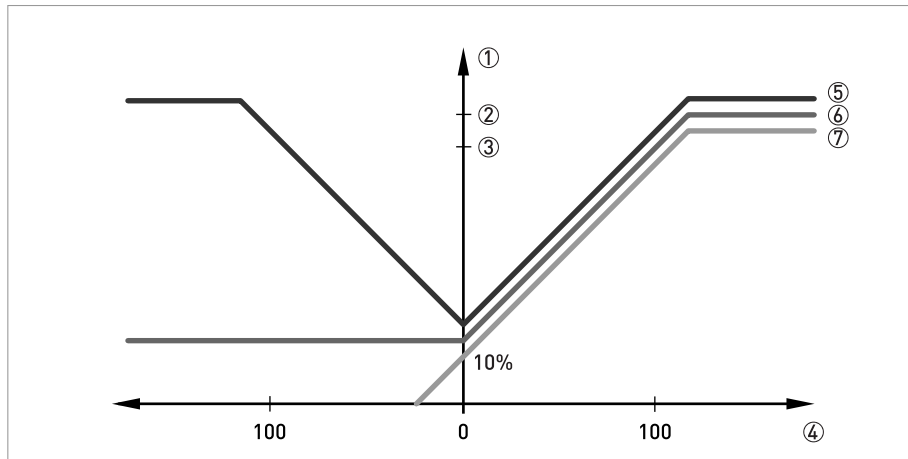

Figure 6-1: Test

- ① I: Axis for current output.
- ② I_{\max} (≤ 22 mA): Current output maximum.
- ③ $I_{100\%}$: Current output at 100% scale.
- ④ Q: Axis for volume flow rate in %.
- ⑤ Selected option: BOTH, reverse flow.
- ⑥ Selected option: FORWARD.
- ⑦ Selected option: F/R SPEC.

6.4.6 User-defined unit for volume flow rate and totalizer (menu 3.07.05...3.07.07)

Any user-defined unit can be programmed. This unit is to be defined as a volume unit per time unit.

- Function 3.07.05: enter the text you want to show at the display.
- Function 3.07.06: enter the amount of the wanted volume units that will fit in a m^3 .
- Function 3.07.07: enter the amount of seconds to equal the wanted time unit.

Example

To program barrels per day

1. Enter "bar/day" in menu 3.07.05.
2. 1 barrel equals $0.159 m^3$, so $1/0.159 = 6.289$ barrels are needed to fill $1 m^3$. Enter "6.289" in menu 3.07.06.
3. 1 day equals 86400 seconds (= $24 \times 60 \times 60$) so enter 8.640E4 in menu 3.07.07 ($8.640E4 = 8.640 \times 10^4$).

6.4.7 Plausibility filter (menu 3.07.09...3.07.11)

A plausibility filter can be set for the sensor measuring paths. There are three settings:

Error limit (menu 3.07.09)

Every measured value outside the error limit is not processed and will increase an internal plausibility counter by 1, until a counter limit has been reached. The corresponding measuring path will then be made inactive.

Range: 1 through 99%, default setting: 20%.



INFORMATION!

Whenever one or more measuring paths are made inactive, the display compass needle will indicate that, combined with the display of error messages.

Error counter decrease step value (menu 3.07.10)

Every measured value within the error limit will decrease the internal plausibility counter by the number programmed in this function. The higher the number, the faster an inactive measuring path will become active again.

Range: 1 through 99, default setting: 4.

Error counter limit (menu 3.07.11)

The counter limit is set using menu 3.07.11. Default setting is 0, i.e. the function is switched off.

7.1 Electronics exchange

7.1.1 Exchange of the electronics unit



DANGER!

All work on the electrical connections may only be carried out with the power disconnected. Take note of the voltage data on the nameplate!



WARNING!

Observe without fail the local occupational health and safety regulations. Any work done on the electrical components of the measuring device may only be carried out by properly trained specialists.

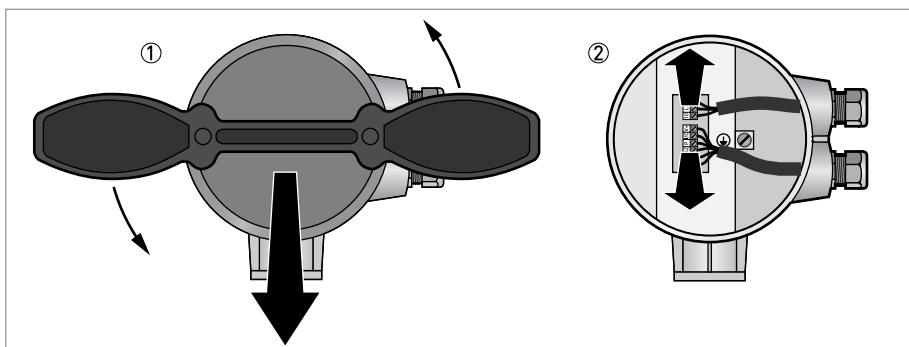

Figure 7-1: Switching off power

- ① Remove the back cover using the wrench.
- ② Disconnect all cables.

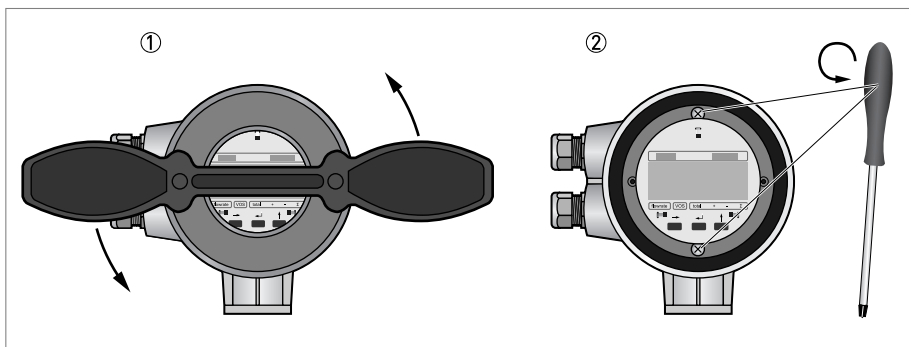

Figure 7-2: Removing display print

- ① Remove the front cover with the wrench.
- ② Loosen the screws of the display.

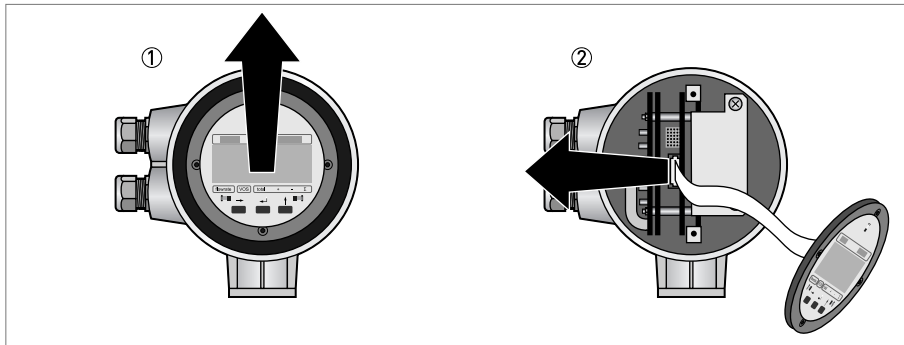

Figure 7-3: Disconnecting display cable

- ① Pull the display towards you
- ② Pull out the connector from the electronics.

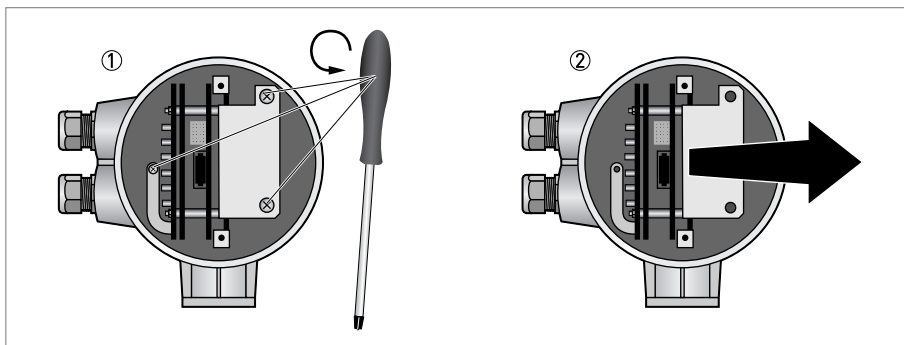

Figure 7-4: Removing electronics unit

- ① Loosen the three screws as indicated.
- ② Take out the electronics unit.

The reassembling takes place in the reverse order. Please regard the following items:



- Sensor specific data must be entered in the converter.
- All application specific settings must be re-entered after replacement of the electronic unit. The supplied report on settings contains the standard factory setting.
- It is recommended to check the zero point and eventually perform a new zero measurement.

7.1.2 Replacing the mains fuse



DANGER!

For continued fire protection or protection against other damage replace the old fuse only with a fuse specified in this section.

Fuse specification

Dimensions	5 x 20 mm (miniature cartridge fuse)
Rated current	230 VAC power supply: 800 mA
	24 VACDC power supply: 1.25 A
Characteristic	Time delay (T)
Rated voltage	250 V
Breaking capacity	1500 A (ceramic body fuse, high breaking capacity)
Standard	IEC 60127-2
Approvals	UL and OR CSA, VDE, SEMKO, BSI

The fuse should not blow normally unless a problem has developed in the instrument. Try to determine and correct the cause of the blown fuse before you replace it. The main fuse can only be reached by removing the complete electronics from the housing as explained in the previous section. Then proceed as follows:

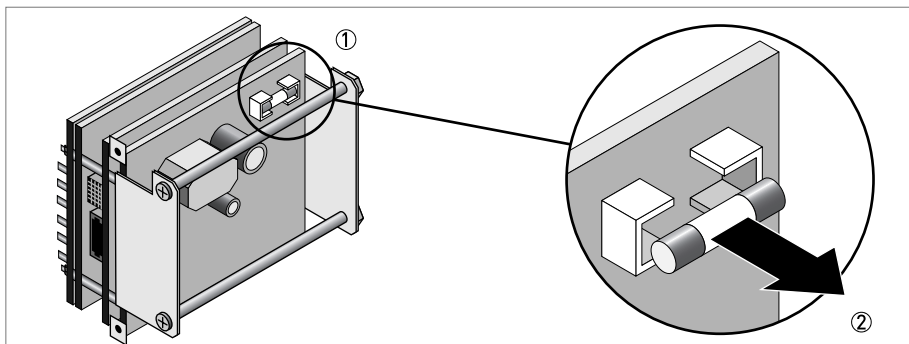

Figure 7-5: Removing fuse

- ① Find the location of the fuse at the power supply board (in this example the 230 VAC version is shown).
- ② Pull out the fuse and replace it.



INFORMATION!

The reassembling takes place in the reverse order.

7.2 Maintenance

Contact your local representative for maintenance or repair.



DANGER!

The following instructions are for use by qualified personnel only. To avoid electric shock, do not perform any servicing other than described in the operating instructions of this manual unless you are qualified to do so.

7.2.1 Admonitions for replacement of flow sensor in separate systems



DANGER!

Always switch off power source before starting work!

Specific calibration data for each flow sensor are determined during factory calibration. Flow sensor specific data must be set in the UFC 030 ultrasonic flow converter when a flow sensor is replaced.



- Enter value of flow sensor primary constant GK in menu 3.01.09 (it is specified on the nameplate).
- If the new flow sensor has a different meter size, you have to program this menu 3.1.8.
- Also set the full-scale range for $Q_{100\%}$ in menu 3.1.1.
- Make a zero check after setting of new data.

7.3 Cleaning



CAUTION!

Scaling at the innerside of the pipe effects the flow measurement. Clean the pipe in such case.



INFORMATION!

Each time a housing cover is opened, the thread should be cleaned and greased. Use only resin-free and acid-free grease.

Ensure that the housing gasket is properly fitted, clean and undamaged.

7.4 Spare parts availability

The manufacturer adheres to the basic principle that functionally adequate spare parts for each device or each important accessory part will be kept available for a period of 3 years after delivery of the last production run for the device.

This regulation only applies to spare parts which are subject to wear and tear under normal operating conditions.

7.5 Availability of services

The manufacturer offers a range of services to support the customer after expiration of the warranty. These include repair, maintenance, technical support and training.



INFORMATION!

For more precise information, please contact your local sales office.

7.6 Returning the device to the manufacturer

7.6.1 General information

This device has been carefully manufactured and tested. If installed and operated in accordance with these operating instructions, it will rarely present any problems.



CAUTION!

Should you nevertheless need to return a device for inspection or repair, please pay strict attention to the following points:

- *Due to statutory regulations on environmental protection and safeguarding the health and safety of our personnel, manufacturer may only handle, test and repair returned devices that have been in contact with products without risk to personnel and environment.*
- *This means that the manufacturer can only service this device if it is accompanied by the following certificate (see next section) confirming that the device is safe to handle.*



CAUTION!

If the device has been operated with toxic, caustic, flammable or water-endangering products, you are kindly requested:

- *to check and ensure, if necessary by rinsing or neutralising, that all cavities are free from such dangerous substances,*
- *to enclose a certificate with the device confirming that it is safe to handle and stating the product used.*

7.6.2 Form (for copying) to accompany a returned device

Company:		Address:	
Department:		Name:	
Tel. no.:		Fax no.:	
Manufacturer's order no. or serial no.:			
The device has been operated with the following medium:			
This medium is:	water-hazardous		
	toxic		
	caustic		
	flammable		
	We checked that all cavities in the device are free from such substances.		
	We have flushed out and neutralized all cavities in the device.		
We hereby confirm that there is no risk to persons or the environment through any residual media contained in the device when it is returned.			
Date:		Signature:	
Stamp:			

7.7 Disposal



CAUTION!

Disposal must be carried out in accordance with legislation applicable in your country.

8.1 Measuring principle

- Like canoes crossing a river, acoustic signals are transmitted and received along a diagonal measuring path.
- A sound wave going downstream with the flow travels faster than a sound wave going upstream against the flow.
- The difference in transit time is directly proportional to the mean flow velocity of the medium.

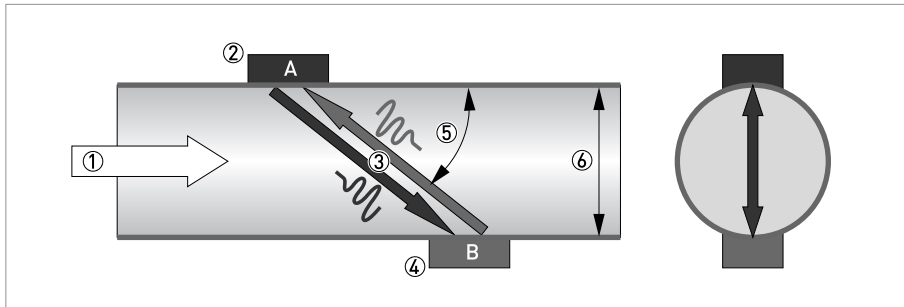

Figure 8-1: Measuring principle

- ① Flow velocity
- ② Transducer A
- ③ Acoustic path
- ④ Transducer B
- ⑤ Angle [between flow vector and acoustic path vector]
- ⑥ Diameter

8.2 Technical data



INFORMATION!

- The following data is provided for general applications. If you require data that is more relevant to your specific application, please contact us or your local sales office.
- Additional information (certificates, special tools, software,...) and complete product documentation can be downloaded free of charge from the website (Download Center).

Measuring system

Measuring principle	Ultrasonic transit time.
Application range	(Non) conductive fluids.
Measured value	
Primary measured value	Transit time.
Secondary measured value	Volume flow rate, totalised volume, velocity of sound (VoS), signal strength, flow direction.

Design

	The measurement system consists of a measuring sensor and a signal converter. It is only available as separate version.
Measuring range	0.5...20 m/s / 1.7...66 ft/s
Signal converter	
Wall-mounted housing (W) - remote version	UFC 030 F
Measuring sensor	
UFS 500 HT is available in the following pipe diameters and building constructions:	
DN25...80 / 0.98...3/15"	Single beam construction.
DN100...300 / 3.94...11.81"	Dual beam construction.
	Larger diameters on request.
Options	
Inputs / outputs	Current (incl. HART®), pulse, frequency and/or status output, limit switch and/or control input (depending on the I/O version)
Counters	2 internal counters with a max. of 8 counter places (e.g. for counting volume and/or mass units)
Display and user interface	
Graphic display	3-Line local display with backlight
	Display turnable in 90° steps
	The readability of the display could be reduced at ambient temperatures below -25°C / -13°F
Operator input elements	3 keys for operator control of the signal converter
	Magnetic pin for operator control of the signal converter (optional)
Remote control	All DTM's and drivers are available at the internet homepage of the manufacturer
	PACTware® including Device Type Manager (DTM)

Display functions	
Menu	Display of volume flow, mass flow, flow speed, velocity of sound, gain, signal to noise ratio, diagnosis value, forward, reverse and counters, warning and diagnosis information, setting parameters via operating menu
Language of display texts	English, French, German

Measuring accuracy

Reference conditions	
	Medium: water
	Temperature: 20°C
	Pressure: 1 bar
	Inlet section: 10 DN
Maximum measuring error	±1% of the measured value for Re > 5000 and v = 1...20 m/s (3.28...65.62 ft/s), temperature influence: 0.1% / 10 K. ±1 cm/s at v < 1 m/s (±0.39"/s at v < 3.28 ft/s)
Repeatability	±0.3%
Calibration	2-point, water, under reference conditions.

Operating conditions

Temperature	
Process temperature	Standard version: -25...+500°C / -13...+932°F Ex version: -25...+440°C / -13...+824°F
Ambient temperature (signal converter)	-40...+65°C / -40...+149°F
Storage temperature (signal converter)	-40...+70°C / -40...+158°F
Pressure	
Ambient	Atmospheric
EN 1092-1	DN200...300: PN10 DN100...150: PN16 DN25...80: PN40 Higher pressure ratings on request
ASME B16.5	1...12": 150 lbs Higher pressure ratings on request
JIS	10K
Medium properties	
Physical condition	Liquids
Permissible gas content (by volume)	<2%
Permissible solid particle content (by volume)	<5%
Viscosity	<100 cSt Higher viscosities on request
Recommended flow velocity	0.5...20 m/s / 1.7...66 ft/s

Installation conditions

Installation	For detailed information refer to <i>Installation</i> on page 12.
Inlet run	DN25...80: ≥ 50 DN
	DN100...300: ≥ 15 DN
Outlet run	DN25...80: ≥ 10 DN
	DN100...300: ≥ 5 DN
Dimensions and weights	For detailed information refer to <i>Dimensions and weight</i> on page 65.

Materials

Sensor	
Sensor material	Measuring tube (DN25...300): Stainless steel 1.4404 (AISI 316L)
	Bundle wave guides: Stainless steel 1.4404 (AISI 316L)
	Connection box: Die-cast aluminium (polyurethane coating)
	Others materials on request
Process connections	
Flange	DN25...300: stainless steel 1.4404 (AISI 316L)
	Others materials on request
Finish (measuring tube)	No paint
Converter	
Housing material	Standard: die-cast aluminum (polyurethane coated)
	Option: stainless steel 1.4404 (AISI 316L)
Finish	Standard: silver paint
	Optional: offshore paint system, silver

Electrical connections

Description of used abbreviations	<p>Q = XXX I_{max} = maximal current U_{in} = XXX U_{int} = internal voltage U_{ext} = external voltage $U_{int, max}$ = maximal internal voltage</p>
Galvanic insulation	All inputs/outputs are standard isolated from the power supply.
Power supply	
Voltage	100...240 VAC (+10% / -15%), 48...63 Hz.
	24 VAC (20...27 V), 24 VDC (18...32 V).
Power consumption	AC: 10 VA
	DC: 8 W
Cable entries (to power supply and sensor)	Standard: M20 x 1.5
	Optional: ½" NPT or PF ½
Cable length	Standard: 5 m / 16.40 ft
	Optional: 10...30 m / 32.81...98.43 ft

Current output	
Function / output data	Measurement of volume flow rate, velocity of sound, signal strength, flow direction.
Settings	Q = 0%: 0...16 mA (HART® versions: 4...16mA, in steps of 1 mA, limit 20...22 mA). Q = 100%: 4...20 mA.
Operating data / Connection	Active mode: $U_{int} = 24$ VDC, maximal load: 680 Ω .
	Passive mode: $U_{ext} \leq 24$ VDC, maximal load: 680 Ω .
Pulse output	
Function / output data	Measurement of volume flow rate, actual volume, velocity of sound, signal strength, flow direction.
Settings	Calculated mass flow rate. Pulse or frequency: 0...2000 Hz, status: on/off.
Operating data / Connection	Active mode: $U_{int} = 24$ VDC, $I_{max} = 50$ mA.
	Passive mode: $U_{ext} = 19...32$ VDC, $I_{max} = 150$ mA.
Analog inputs	
Function / output data	Inputs for calculated (or user defined) mass flow rate.
Settings	For both inputs (A1 and A2): 4...20 mA.
Operating data / Connection	Active mode: $I_{max} = 22$ mA, maximal load: 58 Ω .
	Passive mode: $I_{max} = 22$ mA, maximal load: 58 Ω .
Digital input	
Function / output data	Reset totalised volume, reset errors, force outputs to zero.
Settings	On/off
Operating data / Connection	Active mode: $U_{max} \leq 24$ VDC.
	Passive mode: $U_{max} \leq 24$ VDC.

Approvals

CE	See section 1.3.1.
Hazardous areas	
Ex zone 1	According to European Directive 94/9 EC (ATEX 100a).
FM Div. 1	Approval number 3016332
CSA	Approval number 1515313
Protection category according to IEC 529 / EN 60529	
Sensor	IP65 eq. NEMA 4 / 4X



INFORMATION!

Other diameters, pressure classes or materials than the above-mentioned on request.

8.3 Dimensions and weight

8.3.1 Flow sensors

Front and side view DN25...40 (single beam construction)

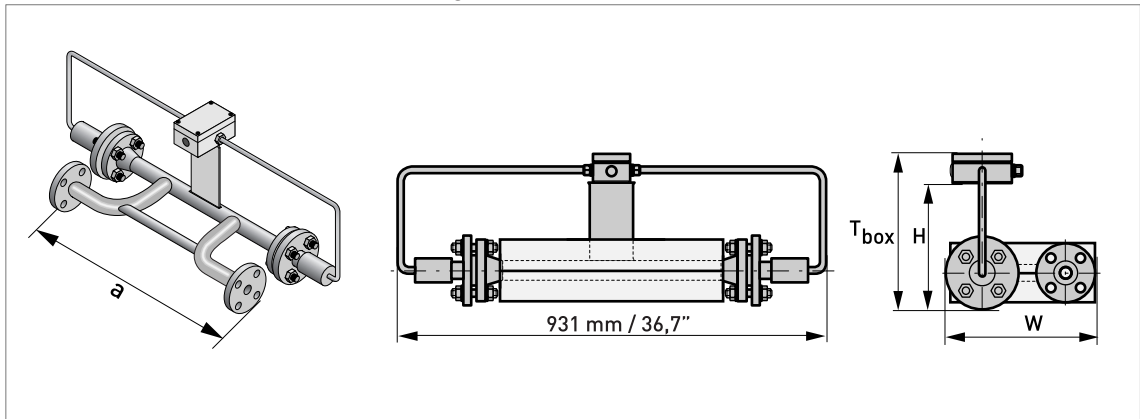

Front and side view DN50...80 (single beam construction)

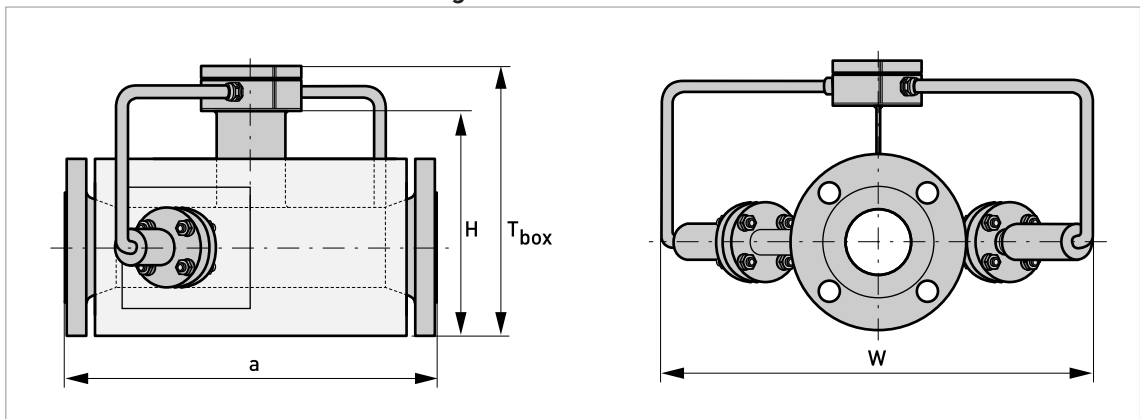

Front and side view \geq DN100 (dual beam construction)

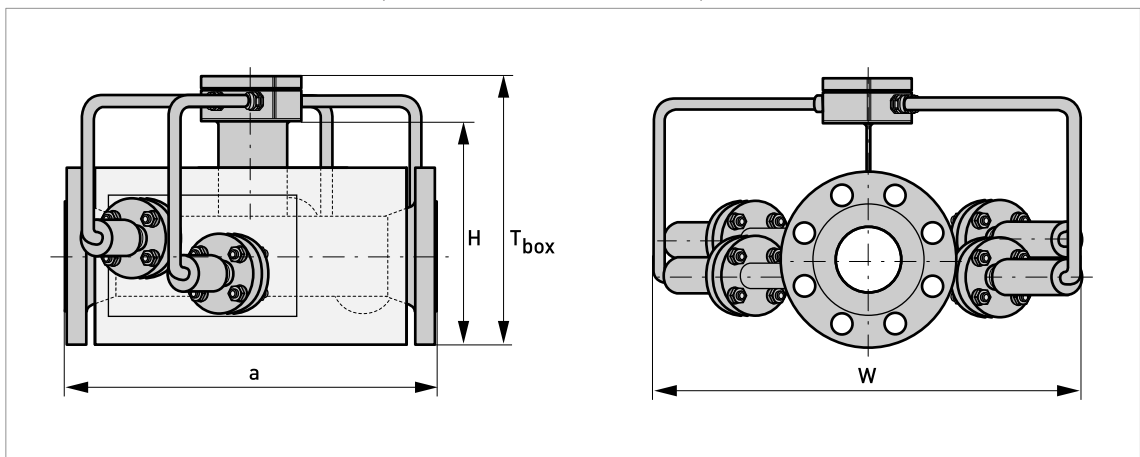

DIN flanges

Nominal size	Nominal pressure	Material	Dimensions [mm]				Approx. weight
DN	[bar]	Tube/Flange	a	W	H	T _{box}	[kg]
25	40	Steel 1.4404	600	310	267	324	28
32	40	Steel 1.4404	600	325	267	324	29
40	40	Steel 1.4404	600	330	270	327	30
50	40	Steel 1.4404	600	500	283	340	27
80	40	Steel 1.4404	700	530	328	385	49
100	16	Steel 1.4404	800	550	353	410	56
150	16	Steel 1.4404	900	610	397	454	76
200	10	Steel 1.4404	1000	660	450	507	84

ASME flanges

Nominal size	Nominal pressure	Material	Dimensions [inch]				Approx. weight
ASME	[lbs]	Tube/Flange	a	W	H	T _{box}	[lbs]
1"	150	SS 316L	23.62	12.40	10.51	12.76	59.5
2"	150	SS 316L	23.62	19.69	10.90	13.15	57.3
3"	150	SS 316L	27.56	20.87	12.21	14.45	72.8
4"	150	SS 316L	31.50	21.26	13.46	15.71	130.1
6"	150	SS 316L	35.43	23.62	15.51	17.76	167.6
8"	150	SS 316L	39.37	25.59	17.80	20.04	229.3
10"	150	SS 316L	39.37	29.13	20.08	22.32	235.9
12"	150	SS 316L	39.37	31.10	20.63	22.87	299.8

**INFORMATION!**

Other diameters, pressure classes or materials than the above-mentioned on request.

8.3.2 UFC 030 signal converter

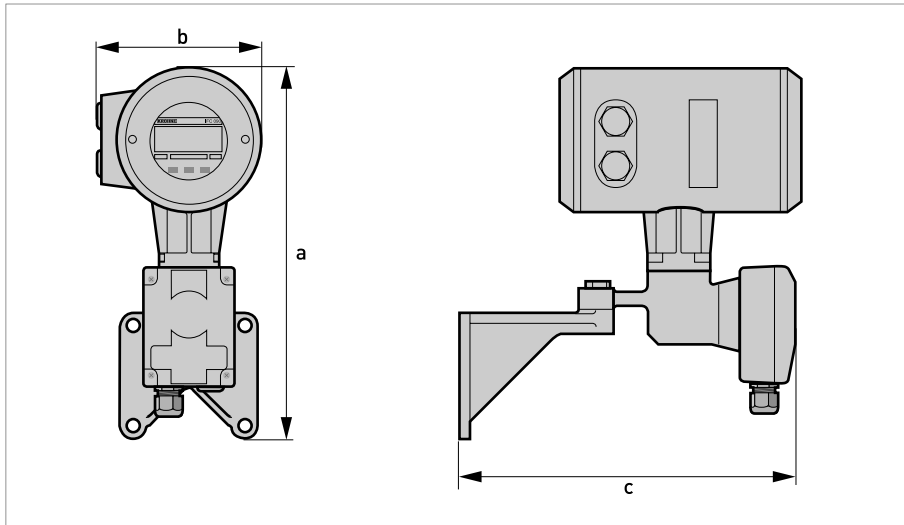

Version	Material	Dimensions [mm / inch]			Approx. weight [kg / lbs]
		a	b	c	
UFC 030 F	Aluminium	315 / 12.40	160 / 6.3	285 / 11.22	4.2 / 9.30
UFC 030 F / EEx	Aluminium	315 / 12.40	160 / 6.3	301 / 11.85	4.5 / 9.90
UFC 030 F / EEx	Stainless steel 1.4404	315 / 12.40	160 / 6.3	320 / 12.60	15/33.10